

## MACHINE TOOLS

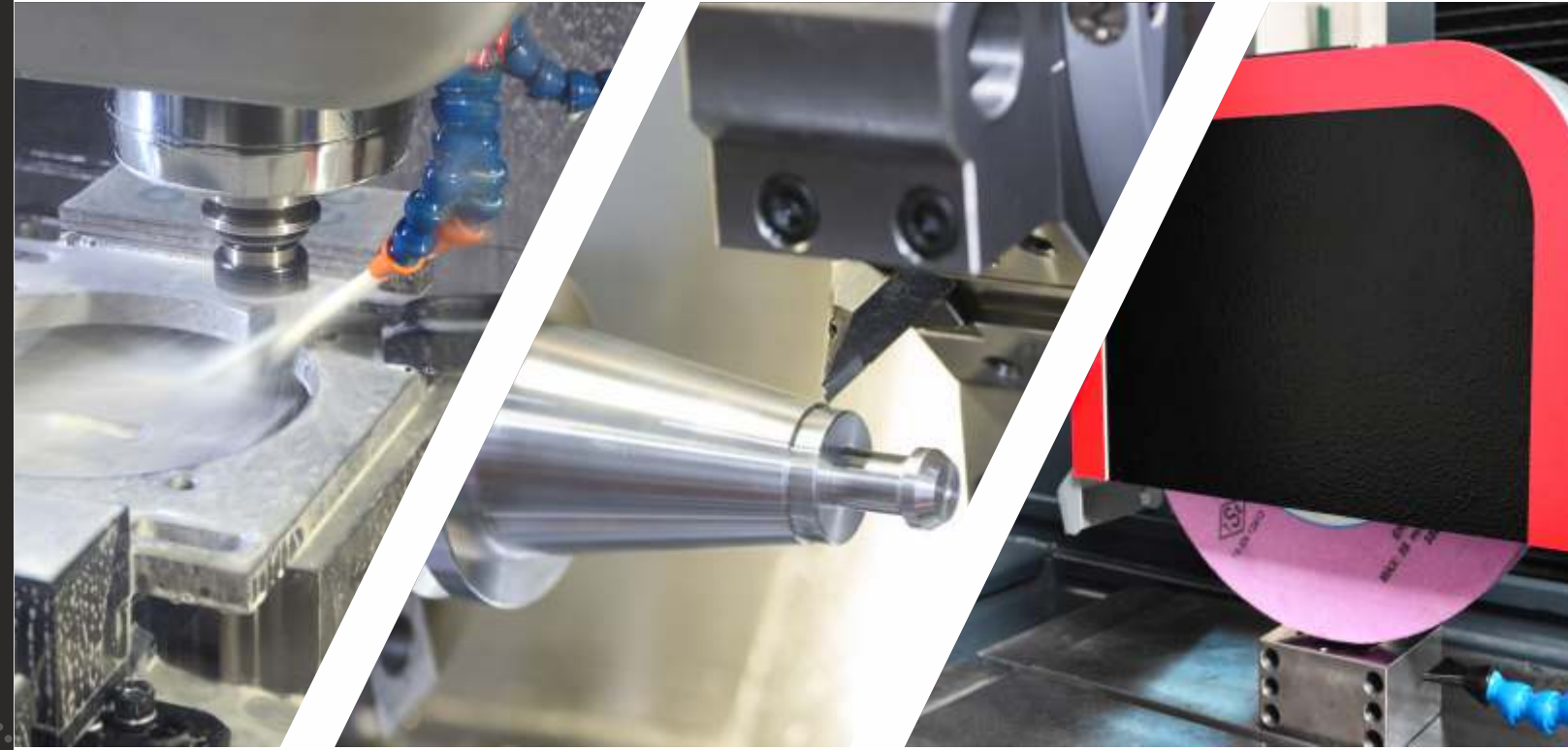

■ CNC VERTICAL MACHINING CENTER



■ CNC LATHE



■ NC HORIZONTAL SPINDLE TYPE SURFACE GRINDING MACHINE



## Engineering the Future

The Dener Machinery Company was established and began its business activities in the Kayseri's industrial zone in 1974. Since its inception, the company has been a market leader in Turkey for CNC Sheet-Metal-Working industry with the decades of experiences, including expert teams in their respective fields. Based on the company's core value of customer satisfaction and seamless service philosophy, it has been manufacturing and marketing higher quality sheet-metal-working machinery from Kayseri to worldwide to contribute to the global economy.

TAKSAN Metal-Cutting-Machinery company was established in 1975 on a 232.000m<sup>2</sup> covered area and 1.850.000m<sup>2</sup> open area for Metal-Cutting-Machinery company acquired Taksan-Metal-Cutting Machinery Company in 2016, and under the DNRdema brand name, it began manufacturing upper segment Metal-Cutting-Machinery since 2016. The Dener Corporation is a cutting-edge and rising company. As a result of DNRdema's expertise and the 21st century's innovative approach, it has continued, with diligent researches to be among one of the world's leading manufacturer. Dener Corporation has been manufacturing for industries in both CNC Metal-Cutting machinery and CNC Sheet-Metal-Working machinery.

The company consist of skilled employee, experienced engineers, and a dedicated R&D team. At the speed Dener Corporation is moving forward, it will surely to be a Global Brand, operating with the latest technology for designing and manufacturing machinery. It will create new trends for the industry and raise customer's expectations.



# INDEX

## CNC VERTICAL MACHINING CENTERS

- 03 Overview
- 04 Standart/ Optional Equipment
- 05 Body structure and Operational area
- 06 Workpiece loading and table measurement
- 07 Tool Changer system
- 08 Chip Conveyor
- 09 Technichal Data

## CNC LATHE

- 11 Overview
- 12 Standart/ Optional Equipment
- 13 Body Structure and Operational Area
- 14 Workpiece Loading and Working Capacity
- 15 Turret and Spindle
- 16 Chip Conveyor
- 17 Technichal Data

## NC HORIZONTAL SPINDLE TYPE SURFACE GRINDING MACHINE

- 19 Overview
- 20 Standart/ Optional Equipment
- 21 Body and Column structure
- 22 Workpiece loading and working capacity
- 23 Control and hydrolic Unite
- 24 Technichal Data

## Overview



Our CNC Vertical Machining Centers assure to achieve optimal performance for all kinds of workpiece. DNR dema is offering longtime industry experiences to meet a wide range of operational needs from high-precision milling under all conditions for drilling, pocketing, boring, screw-cutting to tapping. Furthermore, ergonomical Lcd screen panel with CNC controlling simplifies manual programming and data entry for the machines.

- Custom made double nut screws with high precision and no backlash
- Fast and smooth automatic tool changer system
- Direct drive coupling spindles with high accuracy and rigidity
- High Precision, economical and linear motion
- Effective and smooth motion on linear guide rails or box way rails
- Excellent accuracy of positioning and high-precision for repetitiveness
- Meehanite casting with annealed & stress relieved
- Ensuring quiet, stable and accurate cutting
- Free of charge for assembling machines and educational support domestically
- On-time service with spare parts and delivery



## Standard Equipments

- ✓ Mitsubishi M80A-8A (15" LCD multi-touch colour screen panel)
- ✓ Simple programming function (Navi-Mill)
- ✓ BT 40/10.000 rpm direct drive coupling spindles
- ✓ BT 40 arm type 24 tool storage ATC
- ✓ C3 class double nuts ball-screw
- ✓ Ball type or roller linear motion guide
- ✓ Fully enclosed splash guard
- ✓ Screw-Steelbelt type chip conveyor with chip bucket
- ✓ Centralized automatic lubricating (X/Y/Z)
- ✓ Spindle cooling system
- ✓ Coolant nozzle around spindle
- ✓ Oil Skimmer
- ✓ Rigid tapping
- ✓ Washing the chips system inside cabin
- ✓ Heat exchanger for electrical cabinet
- ✓ Transformer 380/200 v 3 Phase 50/60 Hz
- ✓ LED work light / Program light
- ✓ Air gun / Coolant gun
- ✓ Coolant equipment
- ✓ Remote Handwheel
- ✓ 4th Axis pre-wire (inner cable)
- ✓ Automatic power-off system
- ✓ Foundation bolt kit & Plates
- ✓ Tool box & Tools
- ✓ CE

## Optional Equipments

- ✓ FANUC 0i MF (15" LCD colour screen panel)
- ✓ BT 40/12.000 rpm direct type spindle with spindle oil cooler
- ✓ Coolant through-spindle center (30 bar)
- ✓ Air conditioner for electrical cabinet
- ✓ 4th axis with CNC rotary table
- ✓ Tool length measurements (Renishaw)
- ✓ Workpiece measurement (Infrared Ray & Radio systems)



## Body Structure

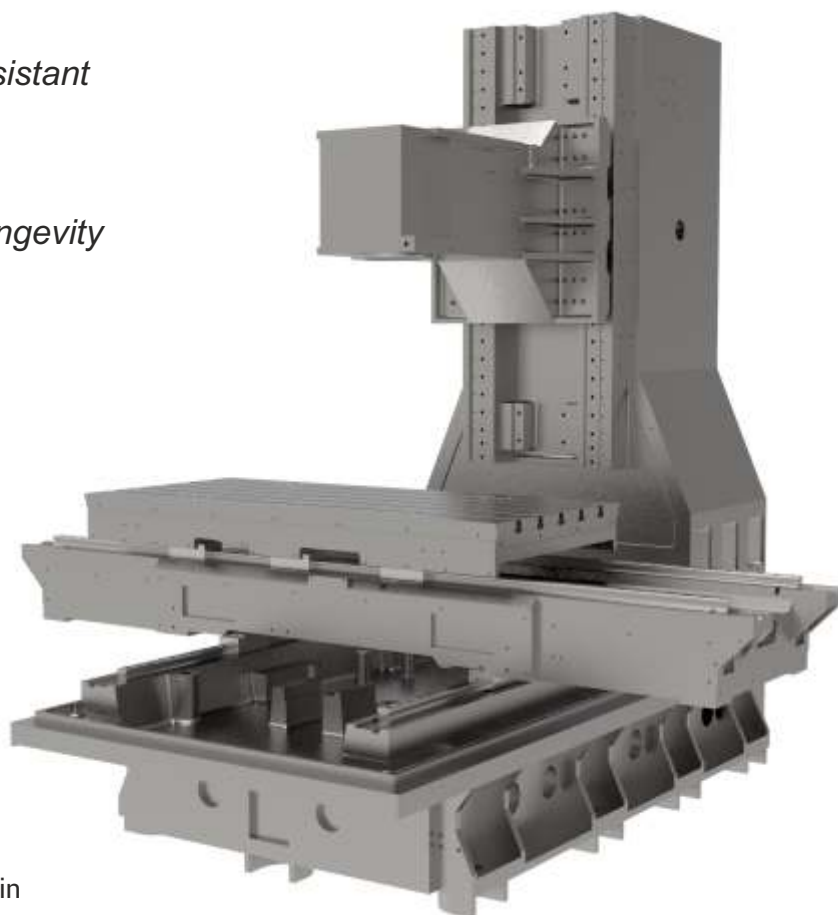
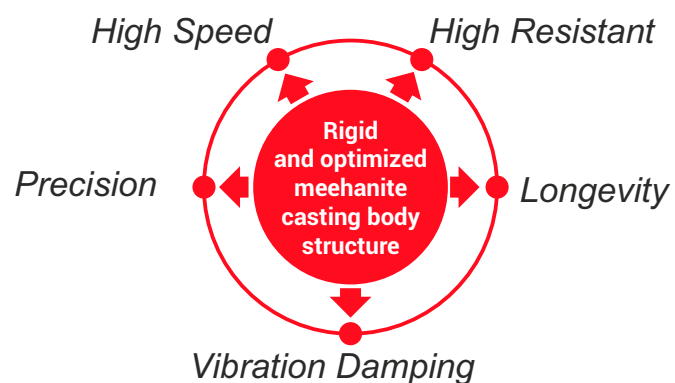

## Working Field

Stroke	X	Y	Z	
EMV-L1150	1150	600	600	mm
EMV-L1300	1300	700	700	mm
EMV-L1600	1600	700	700	mm
EMV-BG1600	1600	800	800	mm

Rapid Axis Speeds	X	Y	Z	
EMV-L1150	36	36	36	m/min
EMV-L1300	36	36	36	m/min
EMV-L1600	30	30	24	m/min
EMV-BG1600	15	15	12	m/min

## Rigid Structure

Based on the combination of deltoid column and main body provides excellent vibration damping and cutting pressure distribution.

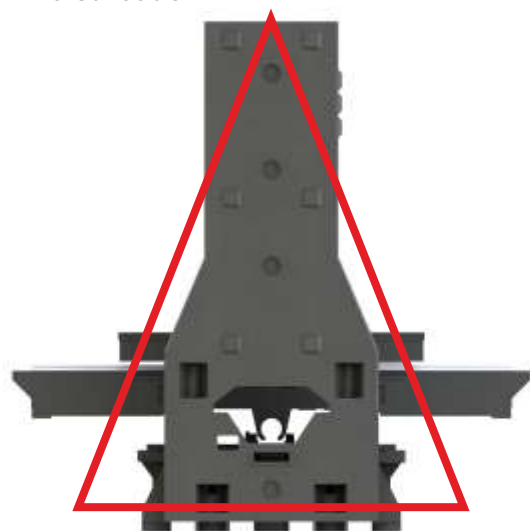

## Finite Element Method

By using the finite element method, optimum body structure is obtained.

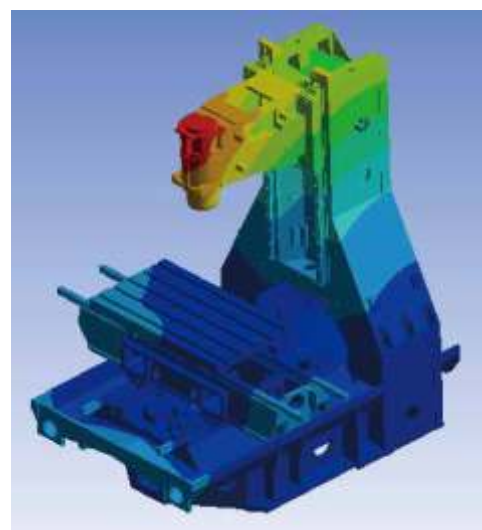

## Work Piece Loading

Loading Capacity	m	
EMV-L1150	1000	kg
EMV-L1300	1200	kg
EMV-L1600	1200	kg
EMV-BG1600	2200	kg

Front Door Opening	a	
EMV-L1150	1215	mm
EMV-L1300	1360	mm
EMV-L1600	1660	mm
EMV-BG1600	1660	mm

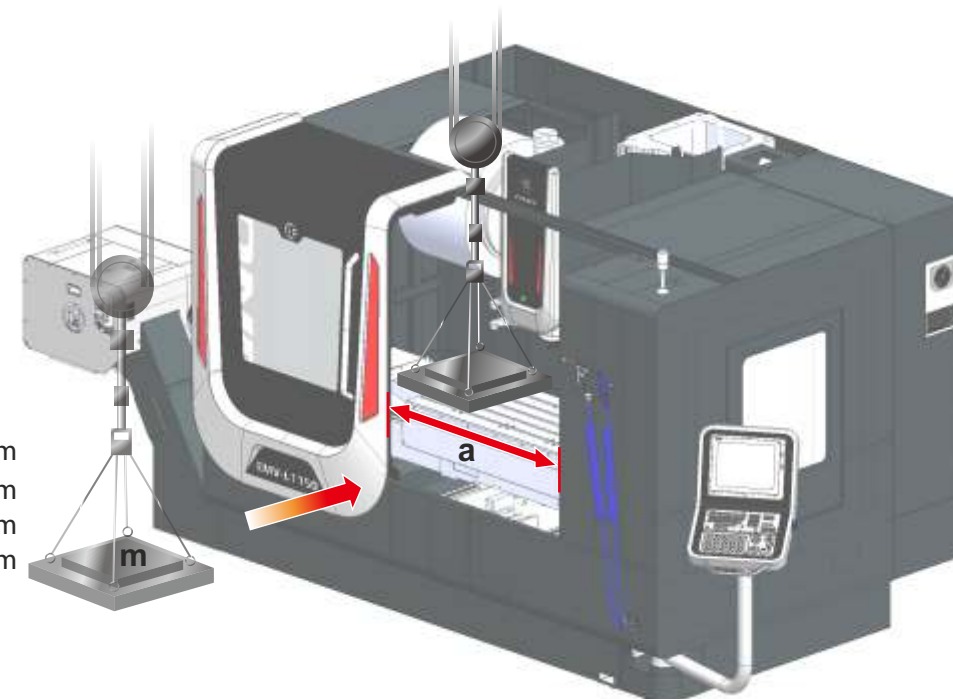

## Table Measurement

Table	L	W	
EMV-L1150	1300	600	mm
EMV-L1300	1450	700	mm
EMV-L1600	1750	700	mm
EMV-BG1600	1800	840	mm

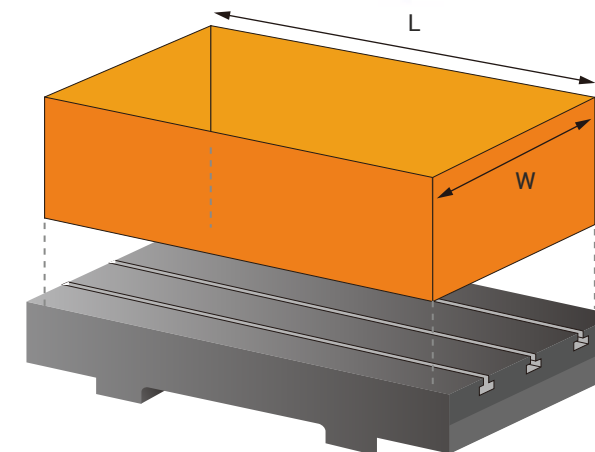

## Extremely Precise Linear Equipment

Precise positioning, repeatability, minimum friction, rigid linear way and extremely precise, grinded, front loading and without back-lash ball-screw and linear way tools in order to operate quiet.



## Direct Drive Servo Motors

Direct drive connection between motor and ball-screw shaft without back-lash and precise motion performance.



## Tool Changer System

Fast, stable and functional tool changing with 24 tool storage capacity, cam typed and inverter controlled ATC.



## Direct-Drive Spindle

Powerful working ability with high heat distribution performance, low vibration, quiet running and easy caring.

	Max. Hz	BT-40	CTS
Std.	10,000 rpm	•	X
Opt.	12,000 rpm	•	•
Opt.	15,000 rpm	•	•



## Spindle Cooling System (Optional)

Automatic controlled cooling system to prevent thermal deformation and to increase longevity of spindle.

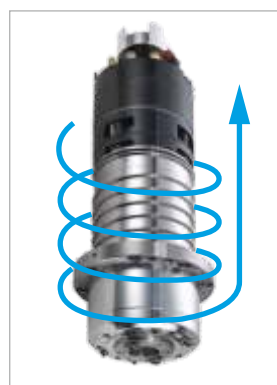

## Cooling through Spindle (Optional)

Excellent cutting ability and longevity of spindle with cooling through spindle.



## Chip Conveyor

Seamless transportation for metal, fiber, teflon, delrin (POM) etc. materials as long, course, spiral chips.



## Coolant Tank

500 lt. capacity, self-filtered and functional tank design provides optimum cooling and easy caring.

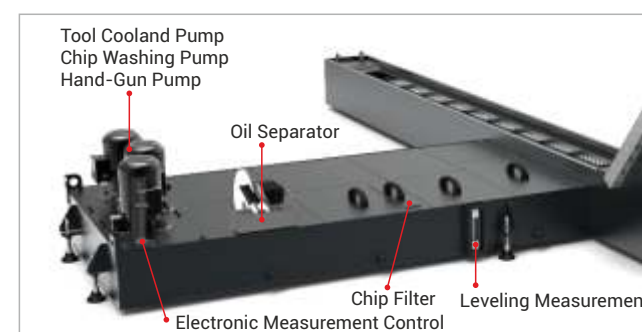

## Chip Bucket

Convertible and braking features provides easy storage and discharge for any kinds of chips.



## Control Unit

Easy to use with current and technologic modules, operator friendly interface and ergonomic design.



			EMV-L 1150 (M)	EMV-L 1300 (M)	EMV-L 1600 (M)	EMV-BG 1600 (M)
Travel	X-Axis Travel	mm	1.150	1.300	1.600	1.600
	Y-Axis Travel	mm	600	700	700	800
	Z-Axis Travel	mm	600	700	700	800
	Ball Screws X/Y/Z	mm	C3 40	C3 45	C3 45	C3 50
	Distance from spindle center to column	mm	717	770	770	870
	Distance from spindle nose to table top	mm	150~760	130~830	130~830	200~1.000
	Guideway type		Roller Type	Roller Type	Roller Type	Box Way
	Guideways X/Y/Z	mm	34/45/45	34/45/45	34/45/45	
Working Table	Table size (X direction)	mm	1.300	1.450	1.750	1.800
	Table size (Y direction)	mm	600	700	700	840
	T-Slot (Size/Q'ty/Dist)		18mm/5/100mm	18mm/5/125mm	18mm/5/125mm	22mm/5/150mm
	Table load capacity	kg	1000	1200	1200	2200
Spindle	Spindle taper		BT 40	BT 40	BT 40	BT 50
	Spindle speed	rpm	10.000	10.000	10.000	6.000
	Spindle driven sytem		Direct-drive	Direct-drive	Direct-drive	Gear Head
Feed Rate	X/Y-axis rapid feed rate	m/min	36	36	30	15
	Z- axis rapid feed rate	m/min	36	36	24	12
	Cutting feed rate	m/min	1~15	1~15	1~15	1~10
Tool Magazine	Tool magazine capacity		24	24	24	24
	Method of tool exchange		Arm type	Arm type	Arm type	Arm type
	Tool change time (Tool-to-tool)	second	1,3	1,3	1,3	1,3
	Max. tool diameter	mm	Ø150	Ø150	Ø150	Ø200
	Max.tool lenght	mm	300	300	300	300
	Max.tool weight	kg	8	8	8	16
Accuracy	Positioning accuracy	mm	0,004	0,004	0,005	0,006
	Repeatability	mm	0,002	0,002	0,002	0,003
CNC Control & Motors	Control system		M80 (FCA80H-8A)	M80 (FCA80H-8A)	M80 (FCA80H-8A)	M80 (FCA80H-8A)
	Screen		15"	15"	15"	15"
	Spindle motor (con./30 min.)	kW	11/15	11/15	11/15	15/18,5
	Spindle motor type		SJ-V15-09ZT	SJ-V15-09ZT	SJ-V15-09ZT	SJ-V18,5-01ZT
	Spindle motor torque	N-m	70	70	70	95,5
	Axis motors X/Y	kW	3,5	4,5	4,5	7
	Axis motors type X/Y		HG354S-D48	HG453S-D48	HG453S-D48	HG703S-D48
	Axis motors torque X/Y	N-m	11,1/22,5/75	14,3/37,2/122	14,3/37,2/122	22,3/49/152
	Axis motor Z	kW	4,5 with brake	7 with brake	7 with brake	7 with brake
	Axis motors type Z		HG453BS-D48	HG703BS-D48	HG703BS-D48	HG703BS-D48
	Axis motors torque Z	N-m	14,3/37,2/90	22,3/49/152	22,3/49/152	22,3/49/152
Coolant Capacity Motor & Pressure & Volume	Coolant pump	kW-(bar)	0,55 - (2)	0,55 - (2)	0,55 - (2)	0,55 - (2)
	Coolant pump for coolant gun	kW-(bar)	0,37-(2)	0,37-(2)	0,37-(2)	0,37-(2)
	Coolant pump for chip clean	kW-(bar)	0,75-(4)	0,75-(4)	0,75-(4)	0,75-(4)
	Coolant tank capacity	liter	500	500	500	500
Air & Power Supply	Air source	bar	6	6	6	6
	Power requiriment	kVA	32	58	48	58
Machine Size	Machine dimensions LxWxH	mm	4.700x3.400x2.600	5.000x3.500x2.800	6.200x3.800x2.800	6.300x3.900x3.300
	Machine weight (approx.)	kg	6.800	8.000	10.000	15.000

## Overview



DNR dema's horizontal CNC Lathe offers high precision inner and outer diameter workpiece operation such as chamfering, forming, inner and outer screw-cuttings and grooving based on desired shapes and size. Moreover, the C axis feature provides the finest facing operation.

- Custom made double nut screws with high precision and no backlash
- Powerful, faster and smooth automatic turret
- High rigidity shafts established on the extraordinary precise ball bearings
- Linear guide way with multi-point roller type bed provides steady cross traveling
- Excellent accuracy of positioning and high-precision for repetitiveness
- Ensuring quiet, stable and accurate cutting
- 45° Slant-bed, solid cast iron for the mono block body
- Free of charge for assembling machines and educational support domestically.
- On-time service with spare parts and delivery



## Standard Equipments

- ✓ FANUC 0i TF-(15" LCD colour screen panel)
- ✓ Roller linear motion guide
- ✓ C3 class double nuts ball-screw
- ✓ BMT type powerful turret
- ✓ Full guarding
- ✓ Steel-belt type chip conveyor with bucket
- ✓ Automatic lubrication
- ✓ Coolant supply equipment
- ✓ Oil Skimmer
- ✓ Transformer 380/200 v 3 Phase 50/60 Hz
- ✓ Foot switch
- ✓ Front door interlock
- ✓ Hydraulic power unit
- ✓ 6"-12" powerful hydraulic chuck and the soft-hard jaws
- ✓ LED work light/Program light
- ✓ Heat Exchanger for electrical cabinet
- ✓ Remote Hand-wheel
- ✓ Levelling bolts screw and plates
- ✓ Tail stock
- ✓ Tool box & Tools
- ✓ CE

## Optional Equipments

- ✓ MITSUBISHI M80A-8A (15" LCD multi-touch colour screen panel)
- ✓ Tool pre-setter
- ✓ Workpiece measurement (in process touch probe)
- ✓ Automatic bar feeder
- ✓ Hydraulic steady rest
- ✓ Air conditioner for electrical box



**Body Structure**

- ▶ High Speed
- ▶ Precision
- ▶ Longevity
- ▶ High Resistance
- ▶ Vibration Damping

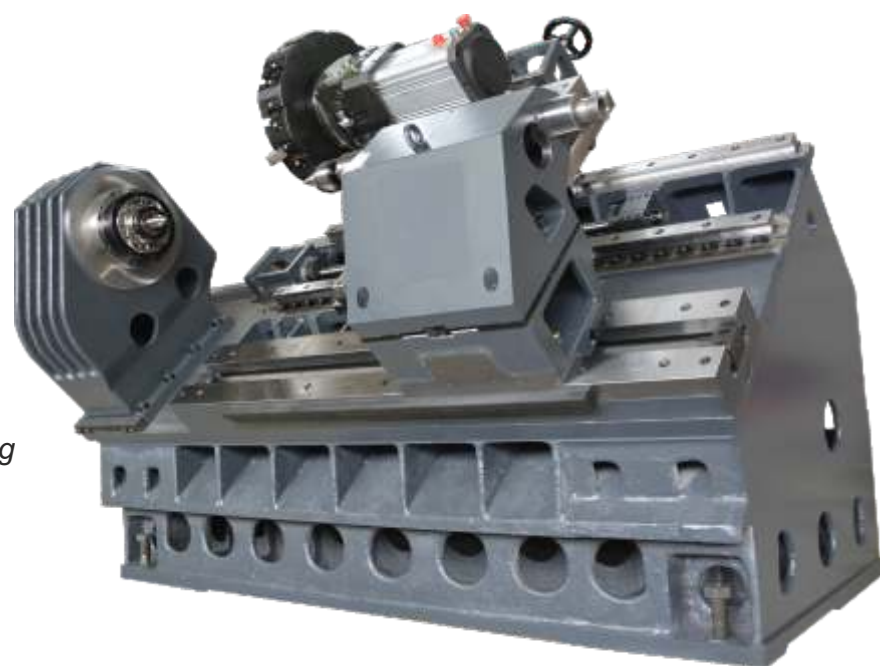

**Working Field**

Stroke	X	Z	
ETH-L 6	180	350	mm
ETH-L 8	240	810	mm
ETH-L10	240	810	mm
ETH-L12	265	1250	mm

Axis Speeds	X	Z	
ETH-L 6	36	36	m/min
ETH-L 8	30	30	m/min
ETH-L10	30	30	m/min
ETH-L12	30	30	m/min

**Rigid Structure**

Effective damping of cutting force while working with 45° angle due to massive main body structure.



**Finite Element Method**

By using the finite element method, optimum body structure is obtained.

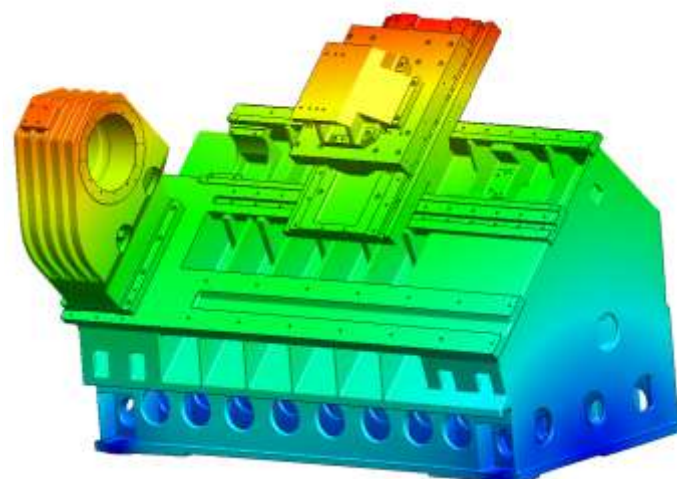

**Work Piece Loading**

Front Door Opening	a	
ETH-L 6	1215	mm
ETH-L 8	1360	mm
ETH-L10	1660	mm
ETH-L12	1660	mm

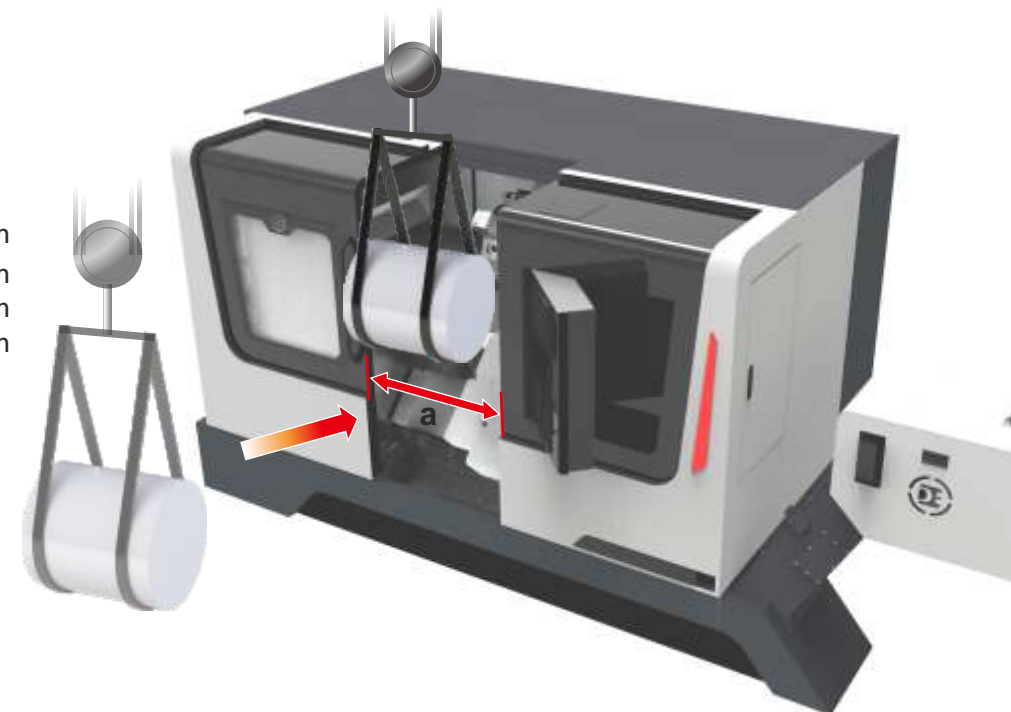

**Operating Capacity**

Capacity	Ø d <sub>1</sub>	Ø d <sub>2</sub>	L	
ETH-L 6	520	300	322	mm
ETH-L 8	600	450	650	mm
ETH-L10	600	450	650	mm
ETH-L12	630	460	1100	mm

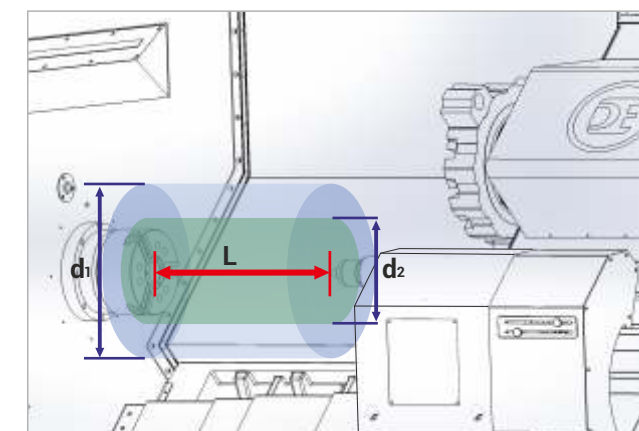

**Extremely Precise Linear Equipment**

Precise positioning, repeatability, minimum friction, rigid linear way and extremely precise, grinded, front loading and without back-lash ball-screw and linear way tools in order to operate quiet.



**Direct Drive Servo Motors**

Direct drive connection between motor and ball-screw shaft without back-lash and precise motion performance.





### Turret

Fast tool changer, high working performance, precise positioning and powerful hydraulic locking with 12 tool storage electro-mechanic servo controlled slot type turret.



### Turret with C Axis (Optional)

C axis working capability, fast tool changer, high working performance, precise positioning and powerful hydraulic locking with new generation BMT type 12 tool storage ( 6 of them lively) electro-mechanic servo turret.

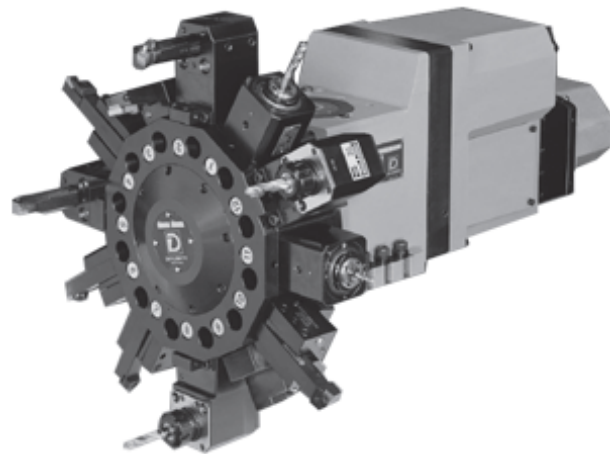

### Spindle

Enhanced with roller linear, possessing high heat distribution performance, low vibration and quiet running capability with high resistance, excellent working.

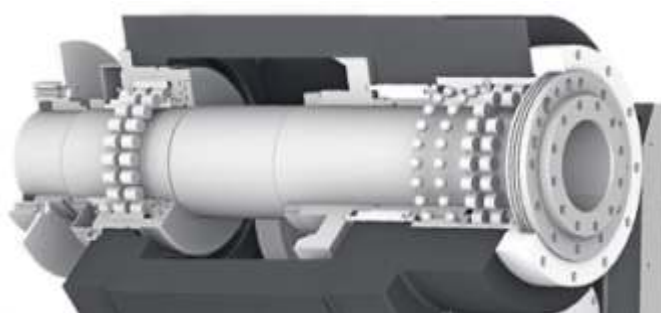

### Mobile Tail-Stock

Easy positioning and powerful braking with independent turret from hydraulic controlled axis movement.

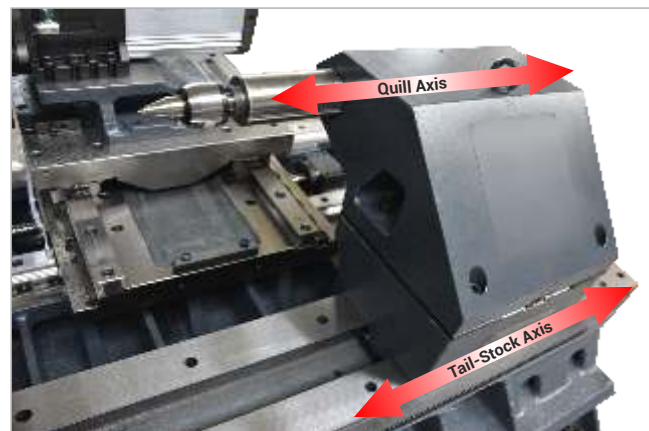
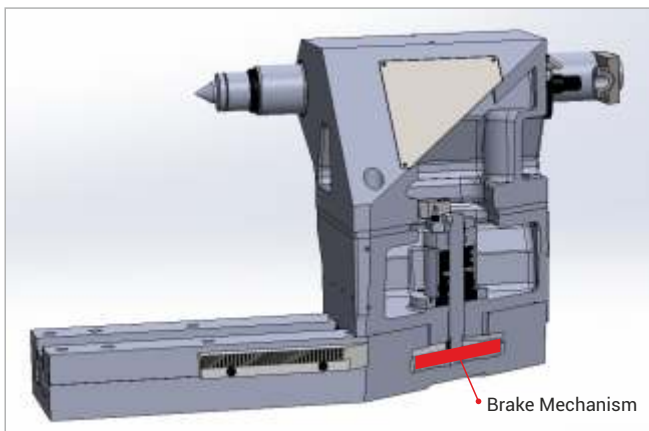

### Chip Conveyor

Seamless transportation for metal, fiber, teflon, delrin (POM) etc. materials as long, course, spiral chips.



### Coolant Tank

140-200 lt. capacity, self-filtered and functional tank design provides optimum cooling and easy caring.

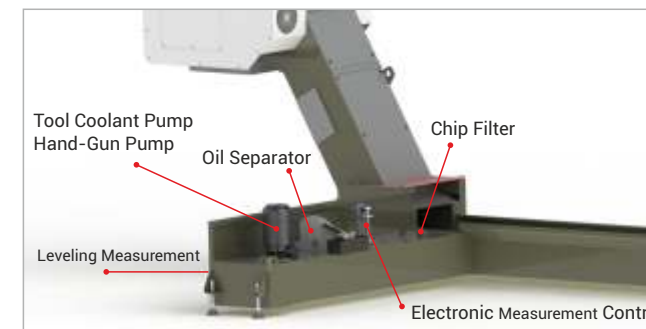

### Chip Bucket

Convertible and braking features provides easy storage and discharge for any kinds of chips.



### Control Unit

Easy to use with current and technologic modules, operator friendly interface and ergonomic design.

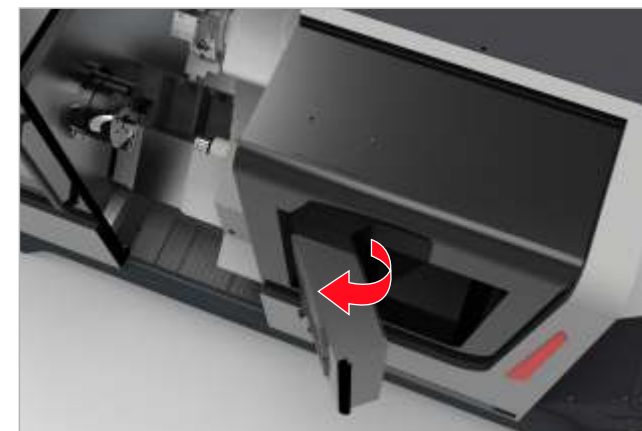



## Overview



Our high-precision surface grinder machine's capability to operate with any kinds of materials for longitudinal and cross directions grinding ensures maximum accuracy.

- 10" user-friendly touch-screen panel
- Vertical and cross travel driven by AC servo motor with ball screw + MPG
- Precise chips removal for cross travelling and vertical axis with NC controlling system
- Electric-Hydraulic system controls the longitudinal travelling
- Ultra-precise, strong, direct-drive without backlash rigid shafts are positioned in multiple locations
- V guide-rails, covered with protective casing, provides finer grinding surface finish
- Hand-scraped prism box guide-rails provides the finest grinding surface finish
- Free of charge for assembling machines and educational support domestically
- On-time service with spare parts and delivery

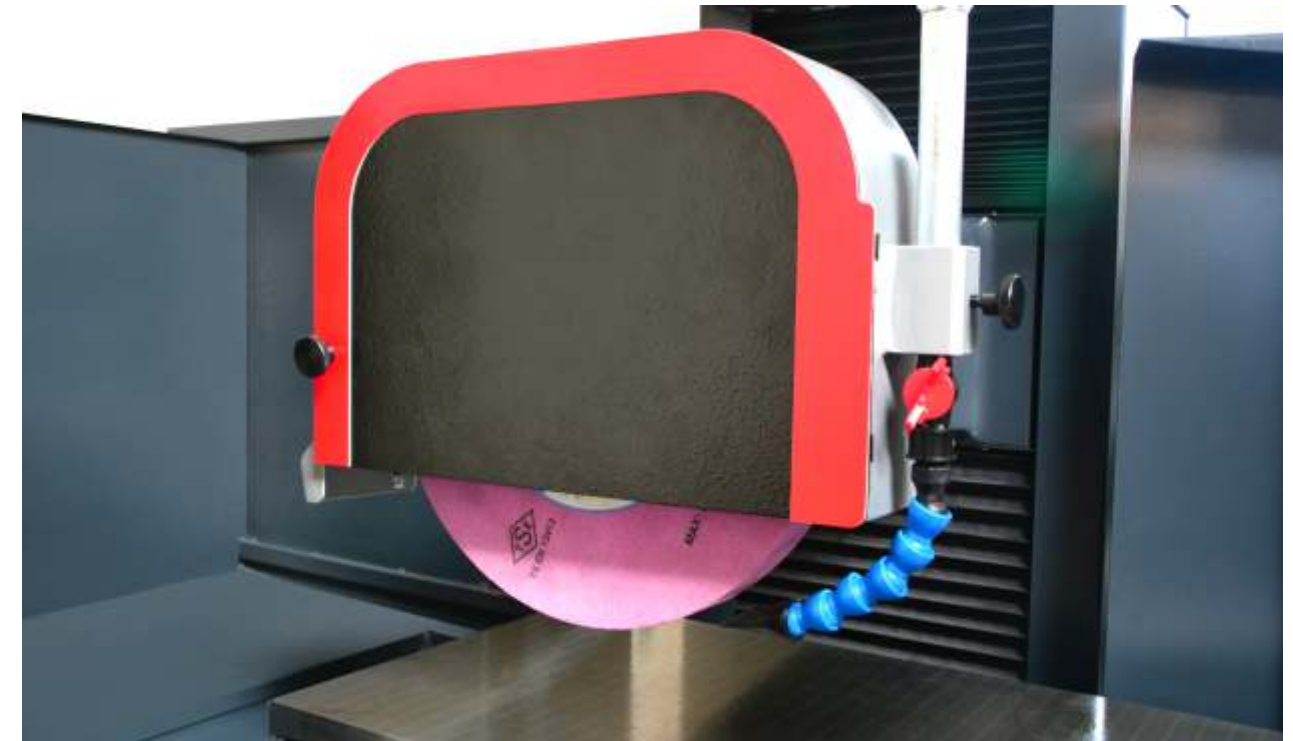

## Standard Equipments

- ✓ Omron NC controls for vertical and cross feed driven axis
- ✓ 10" Colour LCD touch screen panel
- ✓ Remote hand-wheel
- ✓ Semi quarding for table
- ✓ Grinding wheel flange
- ✓ Electromagnetic table (400X800)
- ✓ Balancing arbor
- ✓ Chuck controller for electromagnetic table
- ✓ Leveling bolts & plates
- ✓ Wheel balancing stand
- ✓ Lifting screws
- ✓ Grinding wheel (Ø350xØ127x40)
- ✓ Puller for wheel flange
- ✓ Table type wheel dresser (with the diamond)
- ✓ Coolant equipment
- ✓ Hydraulic unit with the oil (100 Lt)
- ✓ Work light and program light
- ✓ Tools & Box
- ✓ CE

## Optional Equipments

- ✓ Mitsubishi NC controls for vertical and cross feed driven axis
- ✓ Additional wheel flange
- ✓ Parallel wheel dresser on wheel head (with the diamond)
- ✓ Sin bar with magnetic (V-S 100M)
- ✓ Auto paper strip filter with magnetic separator coolant system
- ✓ Tool maker vice (VMV-40)
- ✓ Demagnetizer (for work piece) (VDM-68)
- ✓ Sine bar (VS-100)
- ✓ Punch former with the sine plate (V-PB-BS)

### Body Structure

Stress relieved meehanite casting with annealed body structure provides working under heavy conditions, vibration damping, high precision and high resistance.



### Finite Element Method

By using the finite element method, optimum body structure is obtained.

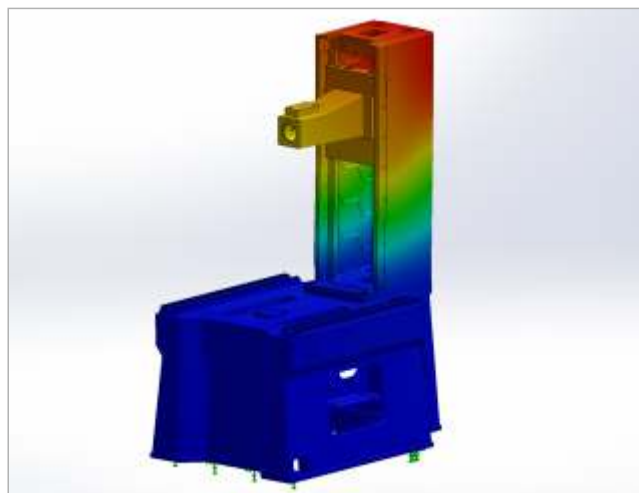

### Column structure

Due to comb support at column, high resistance and vibration damping performance.

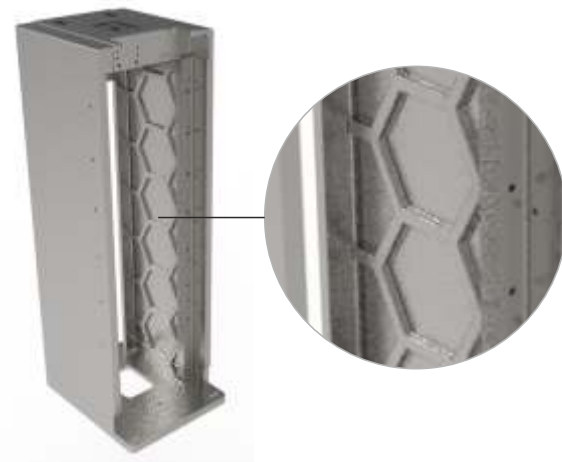

### Linear Guide Way System

Meehanite casting and hand scrapped due to Turcide-B protective casing box-prism rail system precise linear way, positioning and without vibration running.

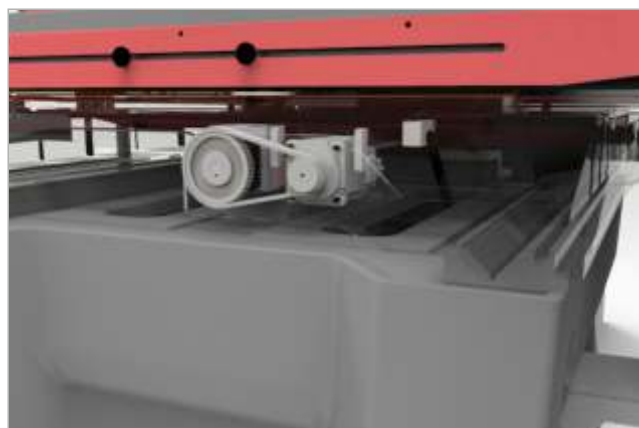

### Operating Field and Table Measurement

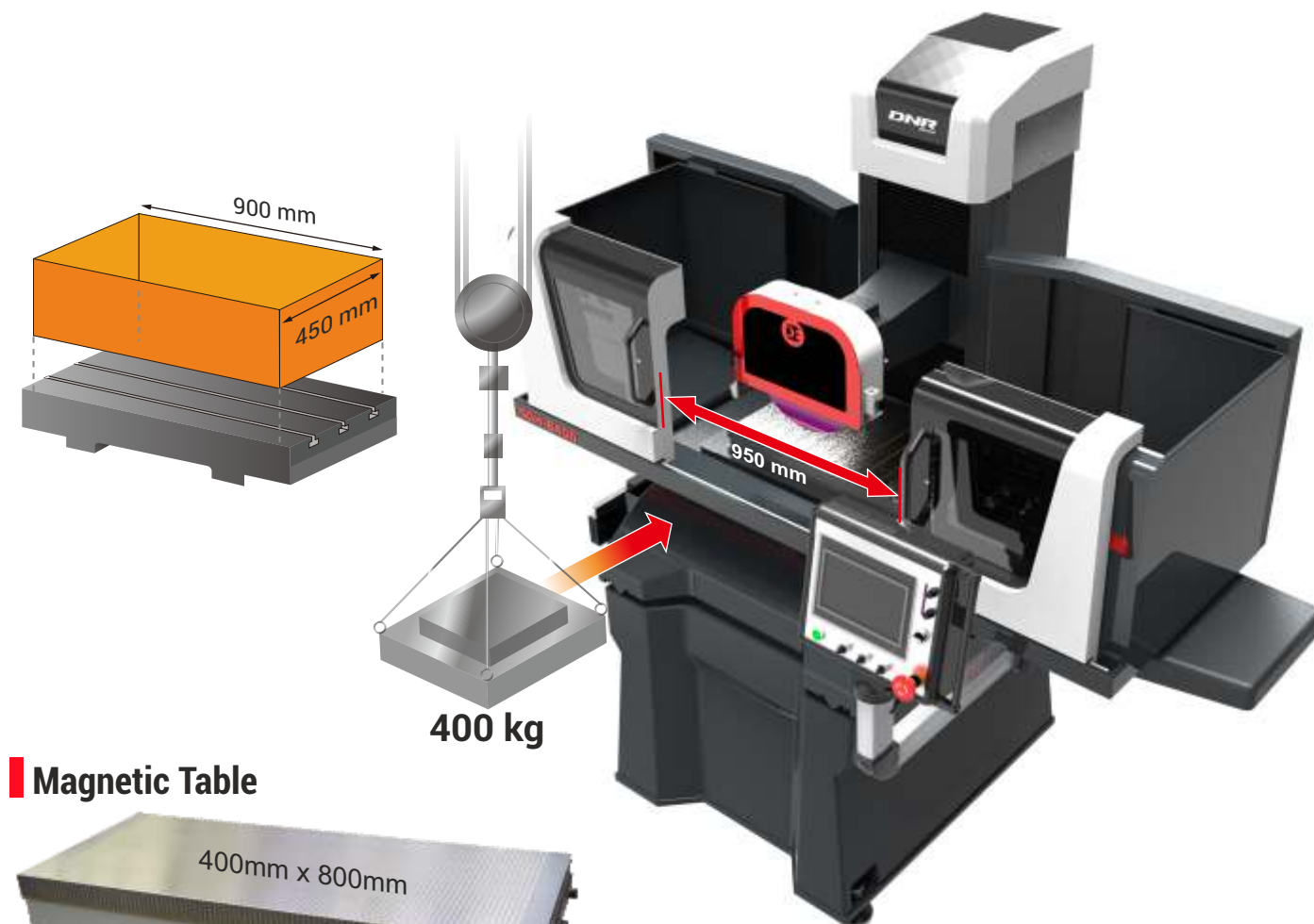

### Magnetic Table



### Column Axis

Hardned and protected casing rails with Turcide-B rigid linear way due to high precision, front loading, grinded ball-screw precise positioning and repeatability.



### Direct-Drive Spindle

Due to direct drive motor connection, pre-loaded and precise roller type bearing supported with spindle provides excellent surface and precise grinding.

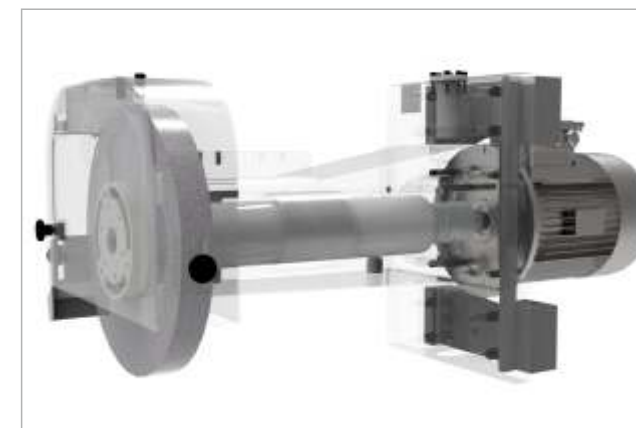

**Control Unit**

Easy to use with current and technologic modules, operator friendly interface and ergonomic design.

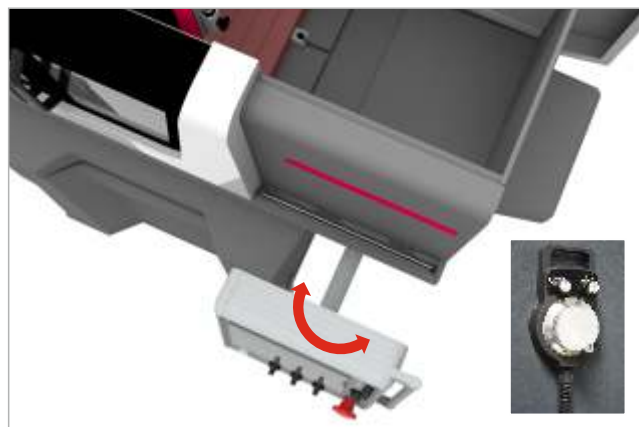

**Coolant Tank (Optional)**

100 lt capacity, self-filtered and functional tank design provides optimum cooling and easy caring.



**Hydraulic Unit**

Due to electronic controlled with hydraulic unit of table axis movement, even if hard conditions, fast and stable working capability.



**Automatic Lubrication System**

By using two different pumps at table axis and all other axis, effective lubrication provides longevity of the equipment.

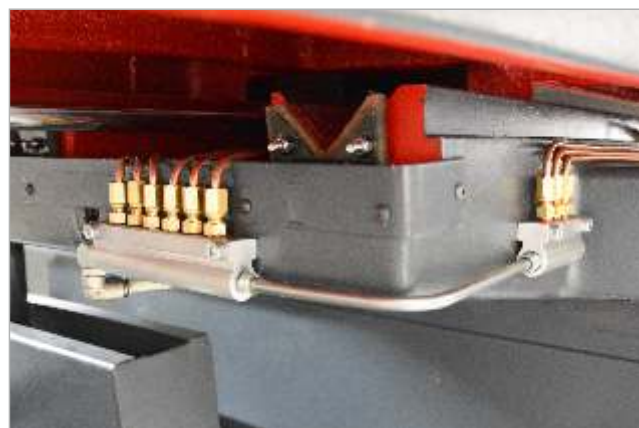

**SGH-B 450 (O)**

Work Table	Table Size	mm	450*900	
	Max. Grinding Length (Longitudinal)	mm	900	
	Max. Grinding Width (Crosswise)	mm	450	
	Max. Distance from Center of Spindle to Table	mm	500	
	Min. Distance from Center of Spindle to Table	mm	75	
	Table Guideway		V&Flat way	
	T-Slot Number/Size		1/14H7	
Ball Screws	Total Max. Safety Table Load	kg	400	
	Ball Screw for Vertical Feed	mm	C3 25	
Traverses Axis	Ball Screw for Cross Feed	mm	C6 25	
	Rapid Power Up/Down	mm/min	6000	
	Rapid Power Cross Feed	mm/min	6000	
	Min. Feeding Setting	mm	0,001	
	Table Speed Approx	Longitudinal	m/min	5~25
		Cross	mm	0,05~20
Auto Feed Increment	Vertical	mm	0,001	
Motors	AC-Spindle Motor Power	kW	4	
	AC-Spindle Motor Speed	rpm	1440	
	Servo-Motor Power for Vertical Feed	kW	0,75	
	Servo-Motor Speed for Vertical Feed	rpm	3000	
	Servo-Motor Type for Vertical Feed		R88M-G75030H-SB2	
	Servo-Motor Torque for Vertical Feed	N-m	2,4	
	Servo-Motor Power for Cross Feed	kW	0,75	
	Servo-Motor Speed for Cross Feed	rpm	3000	
	Servo-Motor Type for Cross Feed		R88M-G75030H-S2	
	Servo-Motor Torque for Cross Feed	N-m	2,4	
	AC-Motor For Longitudinal Axis	kW	4	
	AC-Motor Speed for Longitudinal Axis	rpm	1440	
AC-Lubrication Pump Motor Power	kW	0,048		
Grinding Wheel	Frequency Inverter		3G3MX2-A4040	
	Speed	rpm	100-1500	
	Maximum Speed	rpm	2200	
Power Source	Dimension (OD/ID/W)	mm	Ø350xØ127x40	
	Electric Power Supply (Rated Capacity)	kVA	22,3	
Machine Dimensions	Length	mm	3280	
	Width	mm	2750	
	Height	mm	2151	
	Weight	kg	3700	
Coolant Capacity Motor & Pressure & Volume	Coolant Pump	kW-(bar)	0,2-(0,4)	
	Coolant Tank Capacity	liter	100	
Hydraulic Capacity Motor & Pressure & Volume	Hydraulic Pump	kW-(bar)	4-(40)	
	Hydraulic Tank Capacity	liter	100	
Control Unit	NC System		Omron CP1E	
	Screen		10" Colour Lcd Touch Screen	

