

330

690



www.sayalvinc.com



120°

250°

90

278

330

SAYAL CRANE
POWERFUL LIFTING PARTNER



SAYAL VİNÇ MAKİNA San. ve Tic. Ltd. Şti.

ASO 1.OSB Ahi Evran Mah. Oğuz Cad. No: 41 06935 Sincan - ANKARA / TÜRKİYE

Phone : +90 (312) 267 58 58 **Fax :** +90 (312) 354 58 69

info@sayalvinc.com www.sayalvinc.com





Contents

Table des matieres

ABOUT SAYAL CRANE
Sur Sayal Grue

3

PRODUCTS / Produits

DOUBLE GIRDER OVERHEAD TRAVELLING CRANES
Pont Roulant Bipoutre

4

SINGLE GIRDER OVERHEAD TRAVELLING CRANES
Grues Roulant Bipoutre

6

PORTAL CRANES
Grues Portique

8

TROLLEY HOISTS
Palan Electrique Avec Chariot

12

SY.3.2 AVB • 3200-07 • 3200-10
 SY.5 AVB • 5000-07 • 5000-10 • 5000-12
 SY.6.3 AVB • 6300-07 • 6300-10
 SY.10 AVB • 10000-07 • 10000-10 • 10000-12
 SY.12,5 AVB • 12500-07 • 12500-10
 SY.16 AVB • 16000-07 • 16000-10
 SY.20 AVB • 20000-07 • 20000-10
 SY.25 AVB • 25000-07 • 25000-10 • 25000-12
 SY.32 AVB • 32000-07 • 32000-10 • 32000-12

MONORAIL HOISTS
Grues Monorail

26

SY.3.2 MV • 3200-07 • 3200-10
 SY.5 MV • 5000-07 • 7500-07
 SY.10 MV • 10000-07 • 10000-10
 SY.15 MV • 15000-07 • 15000-10

ENDCARRIAGES SELECTION TABLE
Tableau de Sélection des Sommier

32

ENDCARRIAGES FOR DOUBLE GIRDER O.H.T. CRANES
Sommiers Pour Ponts Roulants Bipoutre

33

2015.GT.X • 2515.GT.X • 3020.GT.X • 3020.GT.U.X
 4020.GT.U.X • 4020.GT.B.U.X • 5025.GT.B.U.X

ENDCARRIAGES FOR SINGLE GIRDER O.H.T. CRANES
Sommiers Pour Ponts Roulants Monopoutre

40

2015.GT.X • 2515.GT.X • 3020.GT.X • 3020.GT.U.X





About Sayal Crane

SAYAL Crane Company Ankara Turkey began as a drive gear and machinery in 2000. Then in 2006, registered all their work in the production of overhead cranes and lifting machines. SAYAL Crane have been able to take its place among the top prestigious corporate sector of experienced and high quality products which include the activities of production and installation of Overhead Cranes and Gantry Cranes. SAYAL is to contribute to increased value to our region and the world as a whole by taking our place among the leading crane manufacturers in the world with the acquisition of technology and advanced production systems



Sayal Crane holds the quality certificate granted by the Turkish Standards Institute for cranes that we produce.

Sayal Grue détient le certificat de qualité délivré par l'Institut Turc de Normalisation pour les grues que nous produisons.

Sur Sayal Grue

La compagnie SAYAL CRANE est situé à Ankara/Turquie, a commencé ces activité dans les années 2000 avec la fabrication de système d'engrenage. Puis en 2006, SAYAL se lance dans la production des ponts roulants et d'engins de levage. La compagnie Sayal CRANE a été en mesure de prendre sa place parmi le secteur des entreprises de prestige, de produits expérimentés et de haute qualité qui comprennent les activités de production, de l'installation des ponts roulants et des grues portiques. L'objectif de la compagnie SAYAL CRANE est de contribuer à accroître la valeur de son expérience dans son ensemble en prenant place parmi les principaux fabricants de grues dans le monde avec l'acquisition de la technologie et des systèmes de production de pointe.



DOUBLE GIRDER OVERHEAD TRAVELLING CRANES

Pont Roulant Bipoutre



Trolley Hoists
Palan Electrique Avec Chariot



Electric Control Panel
Panneau de Commande
d'Electrique



Hook Block
Bloc Crochet



We have the manufacturing up to 100 tons capacities for double girder crane.
Nous avons la fabrication de la pont roulant bipoutre avec la capacité jusqu'à 100 tonnes.

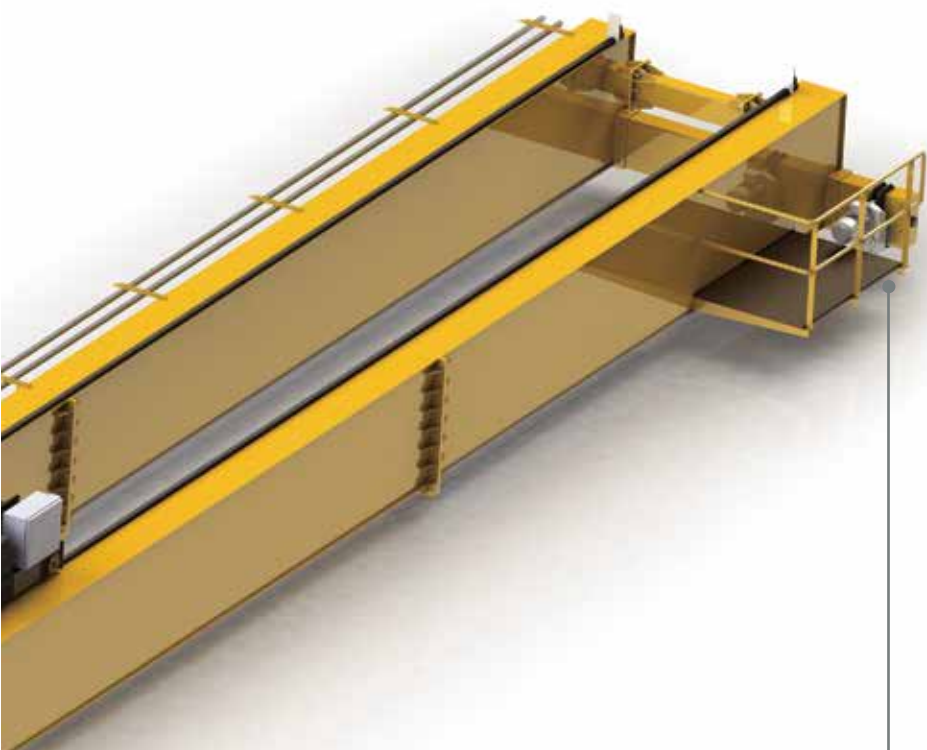

Current Collector
Collecteur de Courant



Travelling Motor
Réducteur Roulant de Pont



Pendant Button
Bouton Pendentif

SINGLE GIRDER OVERHEAD TRAVELLING CRANES

Pont Roulant Monopoutre



Travelling Motor
Réducteur Roulant de Pont

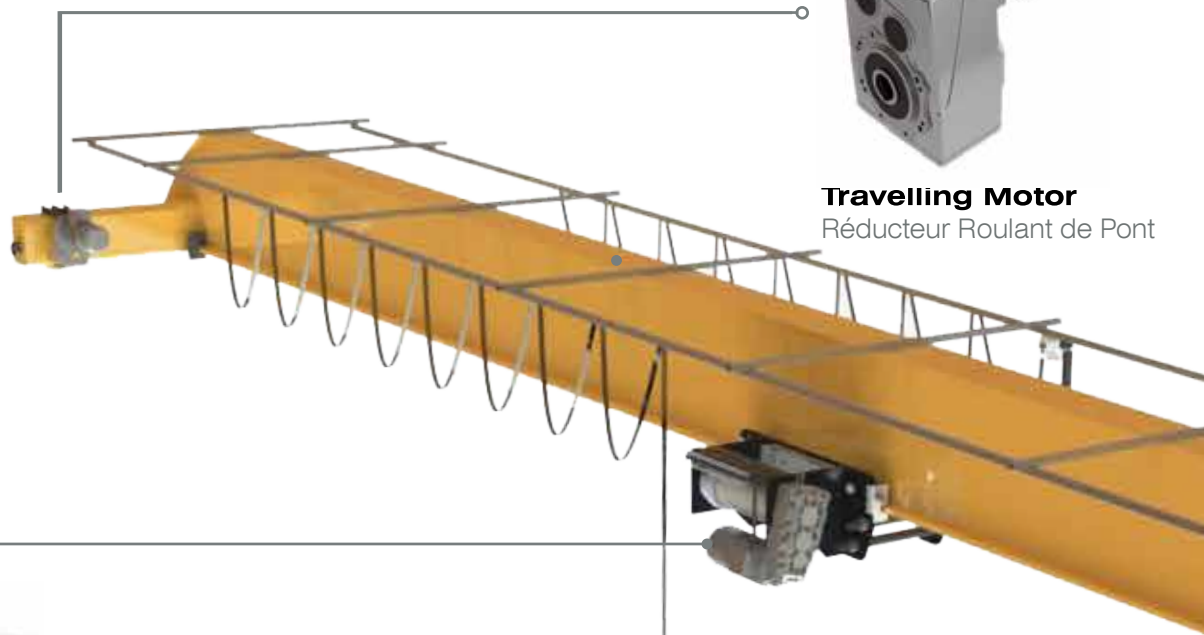

Monorail Hoists
Grue Monorail



Hook Block
Bloc Crochet



Pendant Button
Bouton Pendentif



We have the manufacturing up to 15 tons capacities for monorail crane.

Nous avons la fabrication de la grue monorail avec la capacité jusqu'à 15 tonnes.

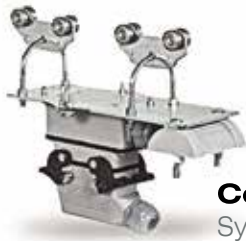

Control Festoon System
Système Contrôle de Feston

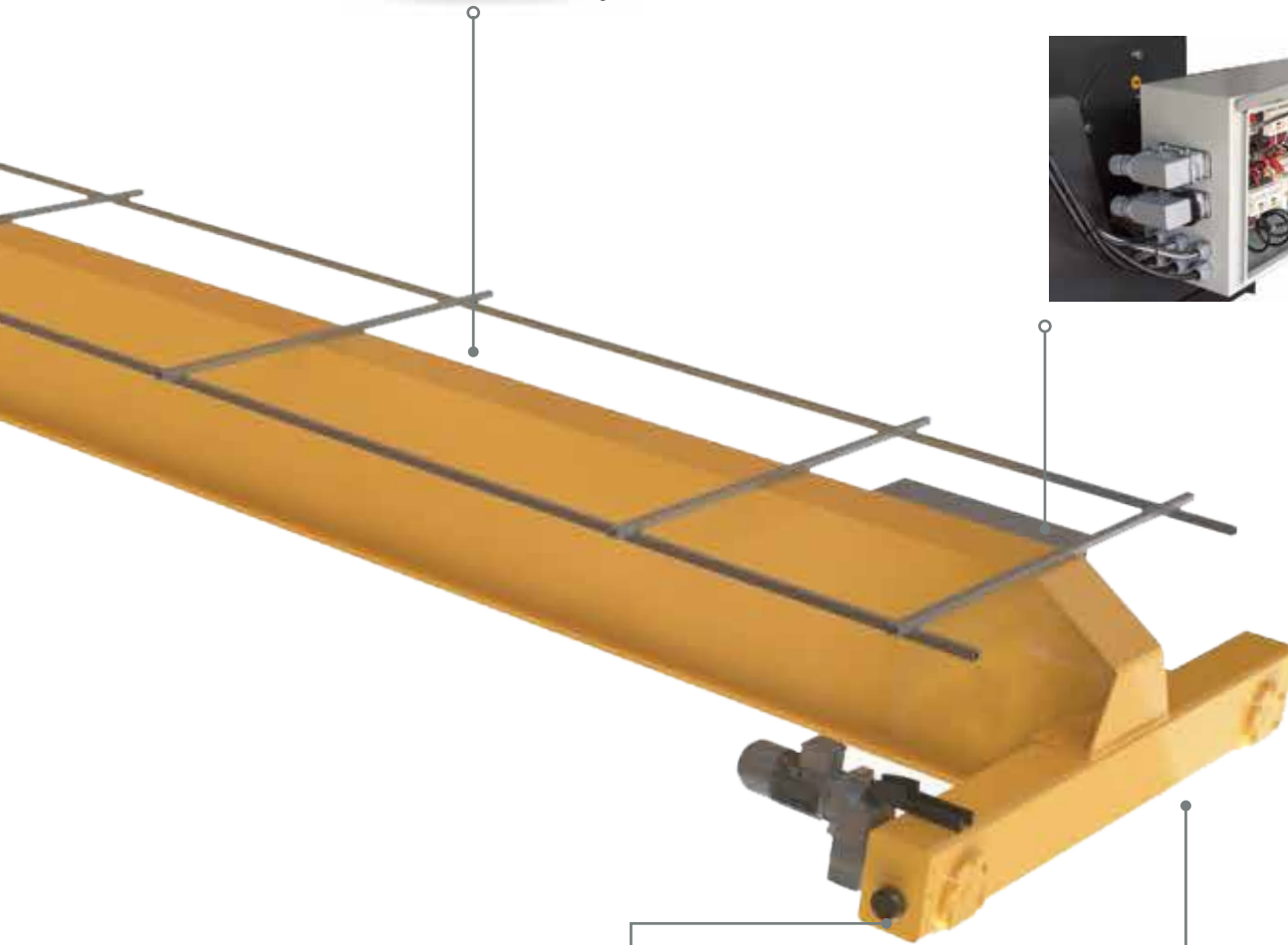

Buffer
Tampon



Current Collector
Collecteur de Courant



PORTAL CRANES

Grues Portique



Cable Reels
Enrouleurs de Câble





Trolley Hoists
Palan Electrique Avec Chariot



Electric Control Panel
Panneau de Commande
d'Electrique

PRODUCE SOLUTIONS SUITABLE FOR YOUR FACILITIES

Nous produisons les solutions appropriées pour vos installations.

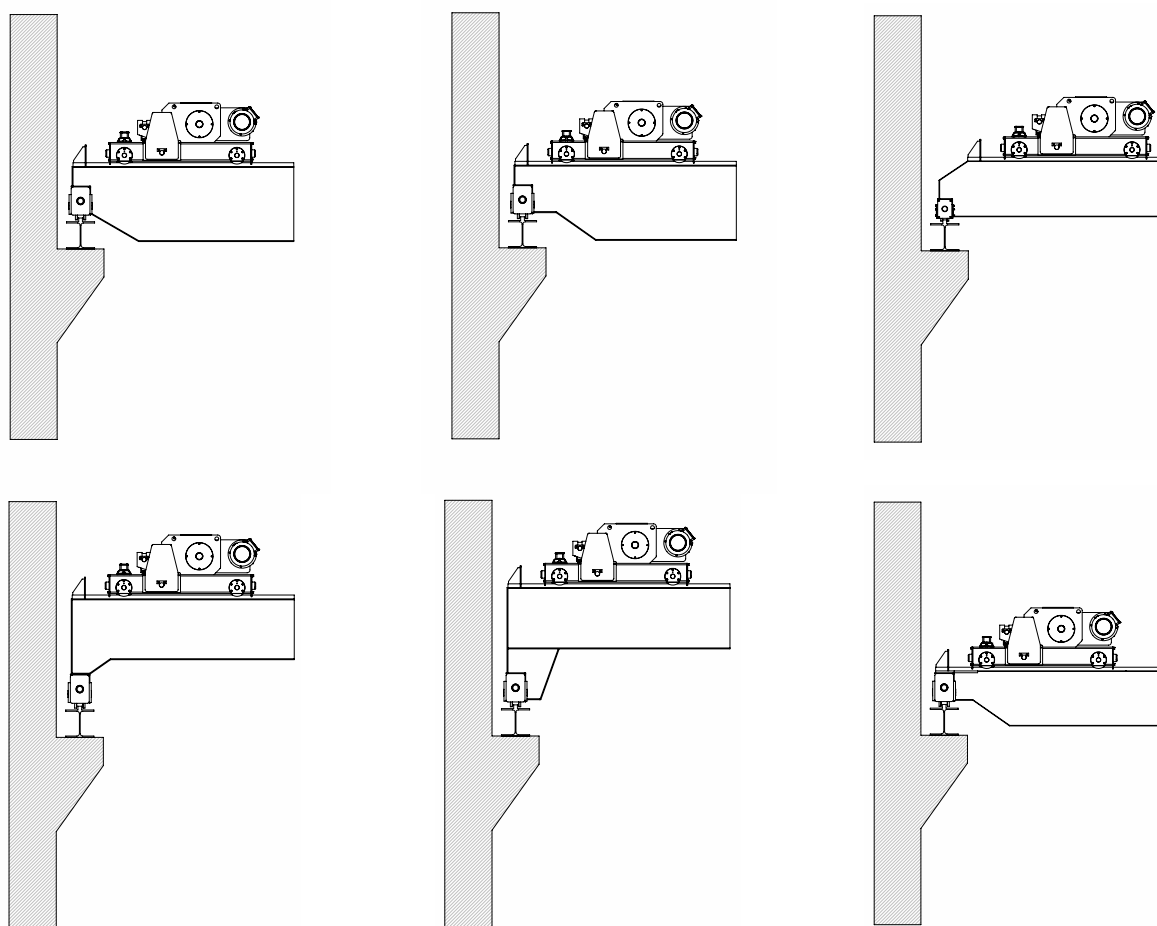



TROLLEY HOISTS

Palan Electrique Avec Chariot

SY.3.2 AVB



TECHNICAL SPECIFICATIONS

Spécifications Techniques

CHASIS Chassis	MODEL Model	TYPE Type	LIFTING CAPACITY (kg) FEM 2M Capacité de levage (kg)	WORKING CLASS	LIFTING HEIGHT (m) Hauteur de levage (m)	LIFTING SPEED TWIN SPEED (m/min.) Vitesse de levage- Vitesse double	TRAVELLING SPEED (m/min.) Vitesse de vehicule (m/min.)	LIFTING MOTOR POWER (kW) Puissance moteur levage (kW)	TRAVELLING MOTOR POWER Puissance moteur vehicule (kW)	ROPE DIAMETER and REEVING Diamètre de corde et de équipement
SY.3.2 AVB	3200-07 3200-10	Double Girder Double Girder	3200 3200	FEM 2m FEM 2m	7 10	0,6 / 3,9	5 / 20	0,37 / 2,5	0,55	8mm-4/1



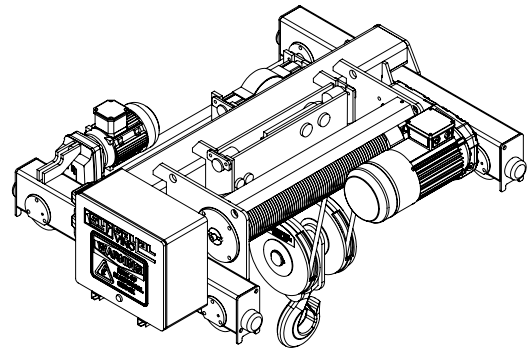
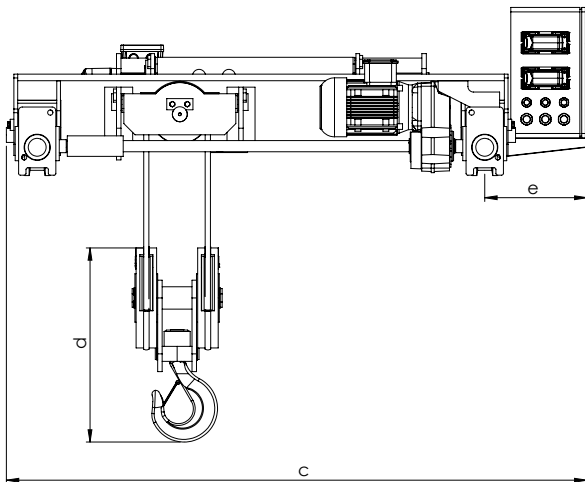
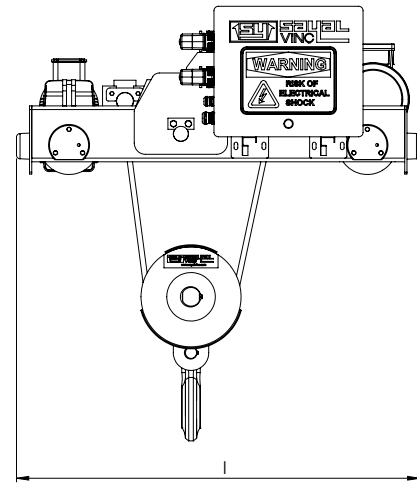
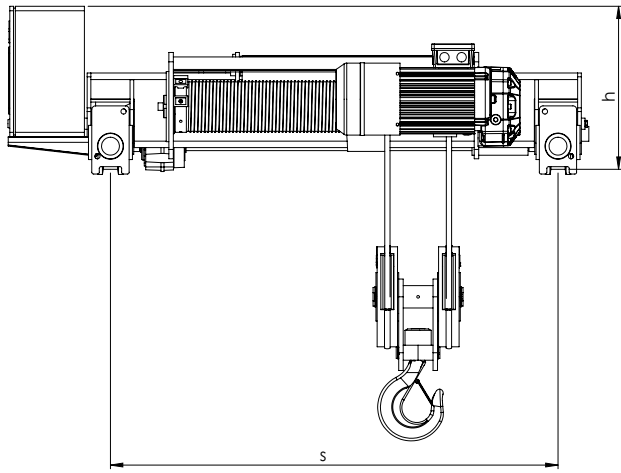

		DIMENSIONS Dimensions						
CHASIS Chassis	MODEL Model	h mm	s mm	l mm	c mm	e mm	d mm	
SY.3.2 AVB	3200 - 07	450	1200	1100	1550	300	530	
	3200 - 10	450	1400	1100	1750	300	530	



TROLLEY HOISTS

Palan Electrique Avec Chariot

SY.5 AVB

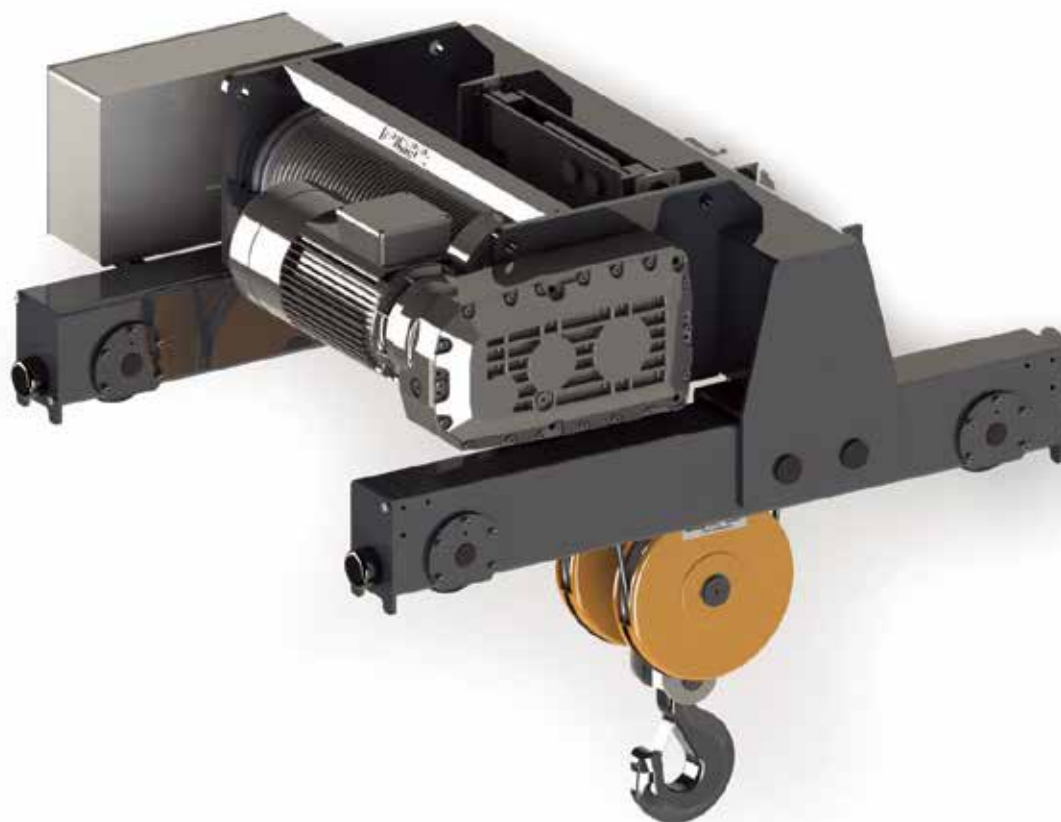

TECHNICAL SPECIFICATIONS

Spécifications Techniques

CHASIS Chassis	MODEL Model	TYPE Type	LIFTING CAPACITY (kg) FEM 2M Capacité de levage (kg)	WORKING CLASS	LIFTING HEIGHT (m) Hauteur de levage (m)	LIFTING SPEED TWIN SPEED (m/min.) Vitesse de levage- Vitesse double	TRAVELLING SPEED (m/min.) Vitesse de véhicule (m/min.)	LIFTING MOTOR POWER (kW) Puissance moteur levage (kW)	TRAVELLING MOTOR POWER Puissance moteur véhicule (kW)	ROPE DIAMETER and REEVING Diamètre de corde et de équipement
SY.5 AVB	5000 - 07	Double Girder	5000	FEM 2m	7	0,8 / 5,2	5 / 20	0,8 / 4,9	0,75	10mm-4/1
	5000 - 10	Double Girder	5000	FEM 2m	10					
	5000 - 12	Double Girder	5000	FEM 2m	12					



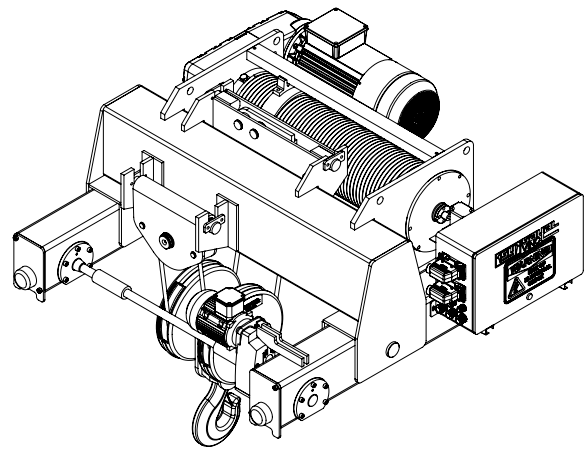
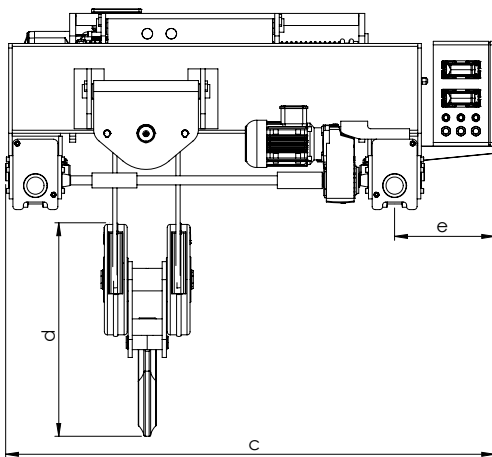
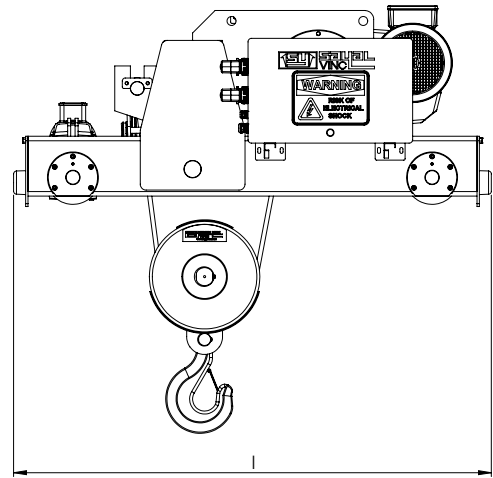
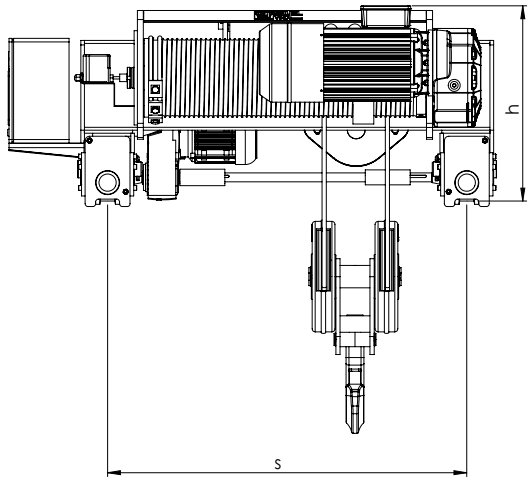

		DIMENSIONS						
		Dimensions						
CHASIS	MODEL	h	s	l	c	e	d	
Chassis	Model	mm	mm	mm	mm	mm	mm	
SY.5 AVB	5000 - 07	500	1000	1300	1450	350	530	
	5000 - 10	500	1200	1300	1650	350	530	
	5000 - 12	600	1400	1300	1850	350	530	

TROLLEY HOISTS

Palan Electrique Avec Chariot

SY.6.3 AVB



TECHNICAL SPECIFICATIONS

Spécifications Techniques

CHASIS Chassis	MODEL Model	TYPE Type	LIFTING CAPACITY (kg) FEM 2M Capacité de levage (kg)	WORKING CLASS	LIFTING HEIGHT (m) Heuteur de levage (m)	LIFTING SPEED TWIN SPEED (m/min.) Vitesse de levage- Vitesse double	TRAVELLING SPEED (m/min.) Vitesse de véhicule (m/min.)	LIFTING MOTOR POWER (kW) Puissance moteur levage (kW)	TRAVELLING MOTOR POWER Puissance moteur véhicule (kW)	ROPE DIAMETER and REEVING Diametre de corde et de équipement
SY.6.3 AVB	6300 - 07	Double Girder	6300	FEM 2m	7	0,7 / 4,2	5 / 20	0,8 / 4,9	0,75	10mm-4/1
	6300 - 10	Double Girder	6300	FEM 2m	10					
	6300 - 12	Double Girder	6300	FEM 2m	12					



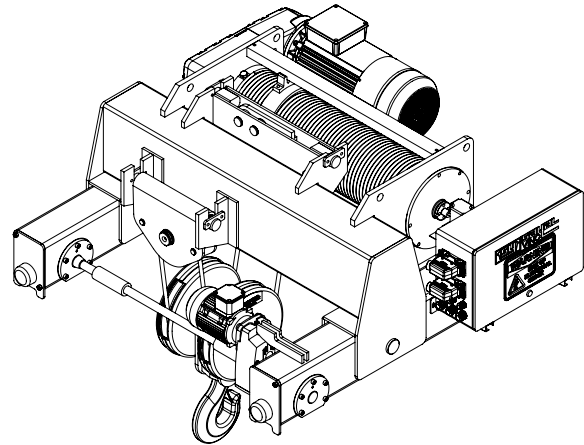
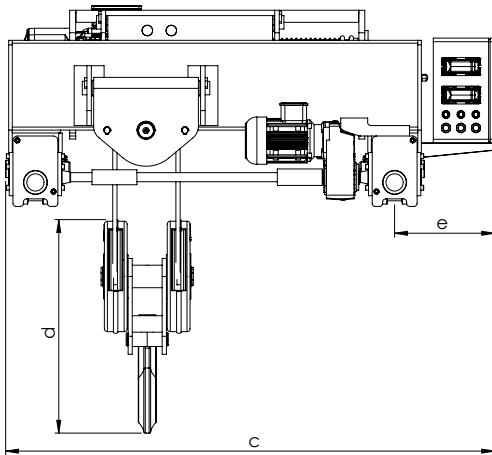
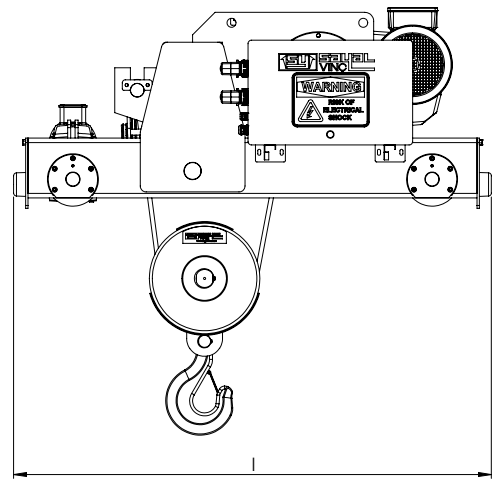
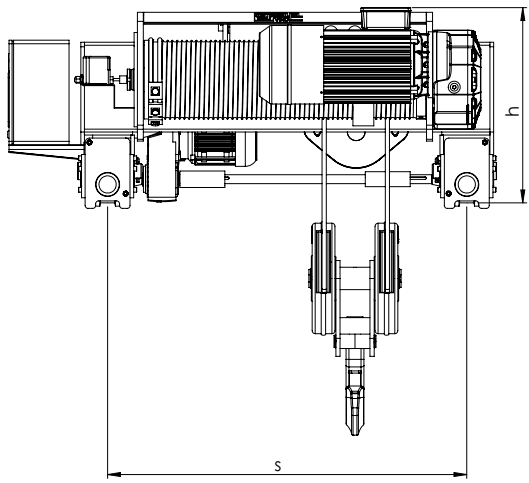

DIMENSIONS
Dimensions

	CHASIS Chassis	MODEL Model	h mm	s mm	l mm	c mm	e mm	d mm
SY.6.3 AVB		6300 - 07	500	1000	1300	1450	350	530
		6300 - 10	500	1200	1300	1650	350	530
		6300 - 12	600	1400	1300	1850	350	530

TROLLEY HOISTS

Palan Electrique Avec Chariot

SY.10 AVB



TECHNICAL SPECIFICATIONS

Spécifications Techniques

CHASIS Chassis	MODEL Model	TYPE Type	LIFTING CAPACITY (kg) FEM 2M Capacité de levage (kg)	WORKING CLASS	LIFTING HEIGHT (m) Heuteur de levage (m)	LIFTING SPEED TWIN SPEED (m/min.) Vitesse de levage- Vitesse double	TRAVELLING SPEED (m/min.) Vitesse de vehicule (m/min.)	LIFTING MOTOR POWER (KW) Puissance moteur levage (kW)	TRAVELLING MOTOR POWER Puissance moteur vehicule (kW)	ROPE DIAMETER and REEVING Diametre de corde et de équipement
SY.10 AVB	10000 - 07	Double Girder	10000	FEM 2m	7	0,7 / 4	5 / 20	1,5 / 9,5	1,1	14mm-4/1
	10000 - 10	Double Girder	10000	FEM 2m	10					
	10000 - 12	Double Girder	10000	FEM 2m	12					



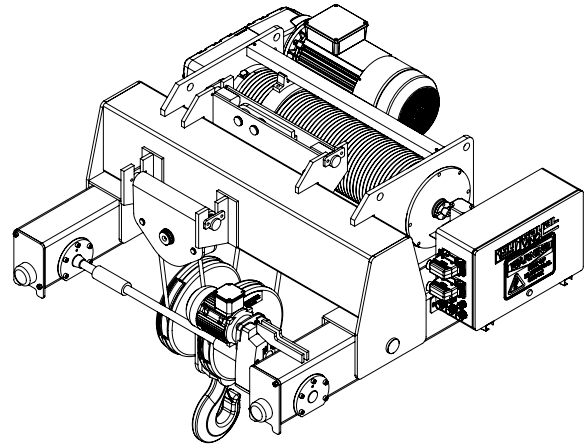
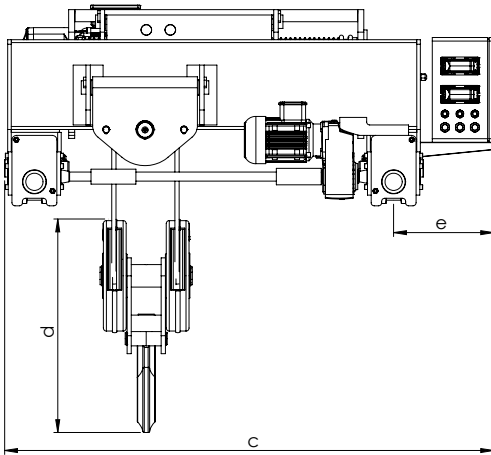
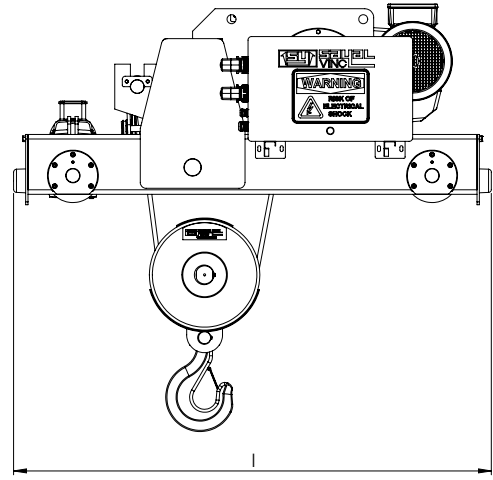
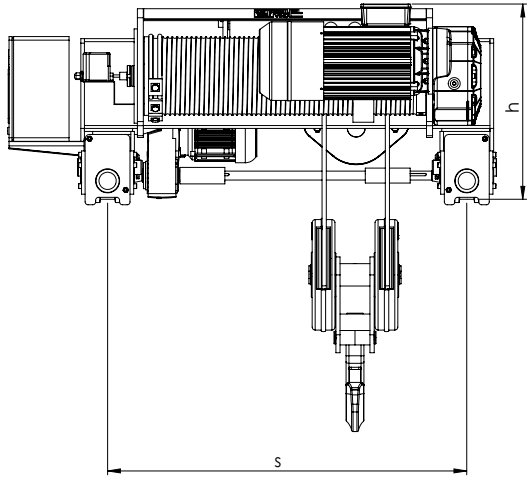

DIMENSIONS
Dimensions

CHASIS Chassis	MODEL Model	h mm	s mm	l mm	c mm	e mm	d mm
SY.10 AVB	10000 - 07	490	1400	1600	1850	350	715
	10000 - 10	660	1200	1600	1650	350	715
	10000 - 12	660	1400	1600	1850	350	715

TROLLEY HOISTS

Palan Electrique Avec Chariot

SY.12.5 AVB

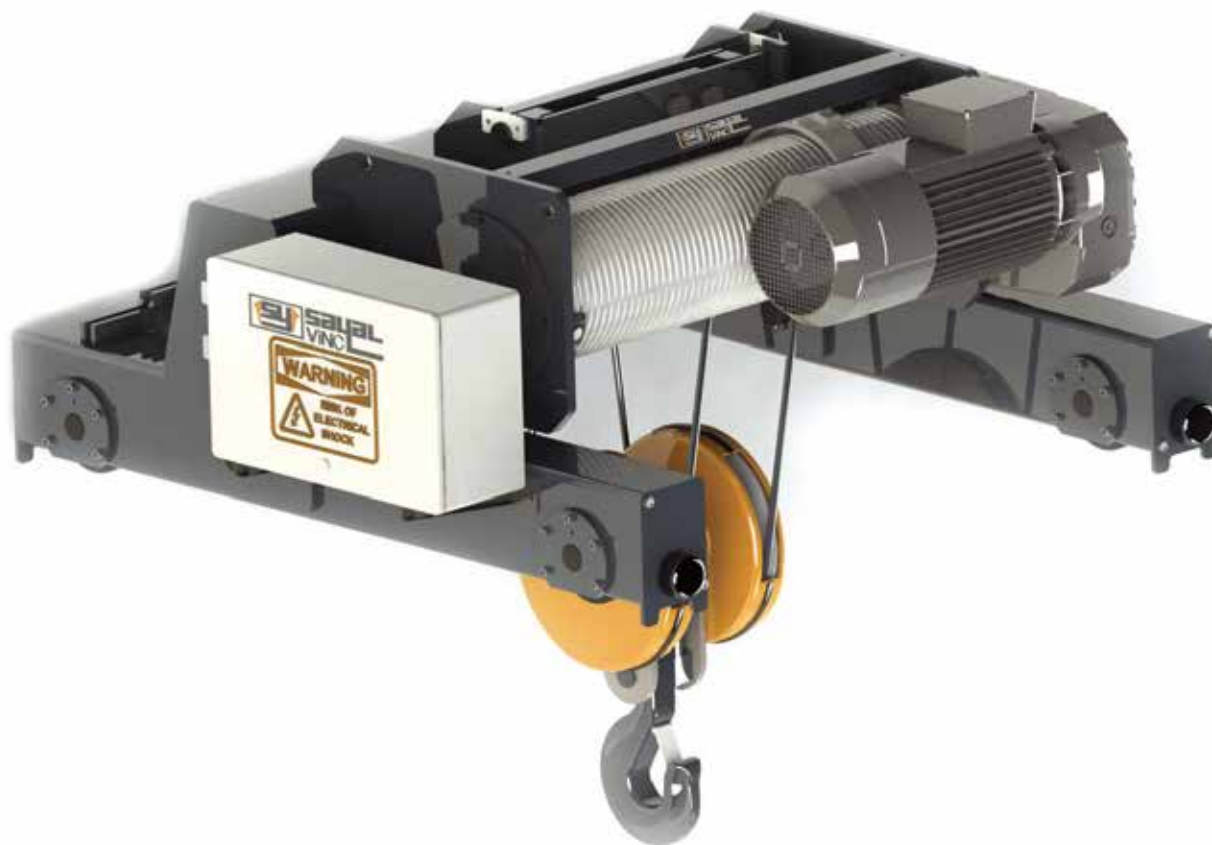

TECHNICAL SPECIFICATIONS Spécifications Techniques

CHASIS Chassis	MODEL Model	TYPE Type	LIFTING CAPACITY (kg) FEM 2M Capacité de levage (kg)	WORKING CLASS	LIFTING HEIGHT (m) Hauteur de levage (m)	LIFTING SPEED TWIN SPEED (m/min.) Vitesse de levage- Vitesse double	TRAVELLING SPEED (m/min.) Vitesse de vehicule (m/min.)	LIFTING MOTOR POWER (kW) Puissance moteur levage (kW)	TRAVELLING MOTOR POWER Puissance moteur vehicule (kW)	ROPE DIAMETER and REEVING Diametre de corde et de équipement
SY.12,5 AVB	12500 - 07	Double Girder	12500	FEM 2m	7	0,7 / 4	5 / 20	1,5 / 9,5	1,1	14mm-4/1
	12500 - 10	Double Girder	12500	FEM 2m	10					
	12500 - 12	Double Girder	12500	FEM 2m	12					



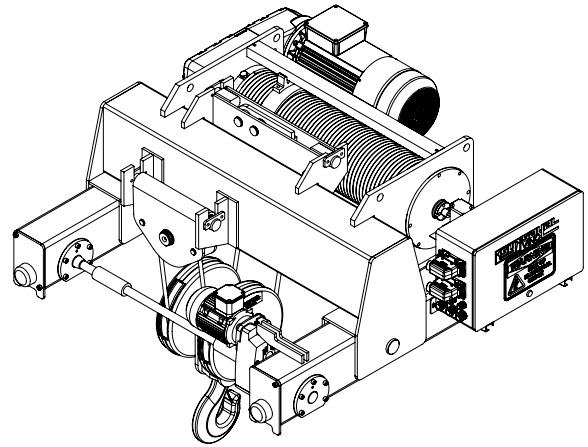
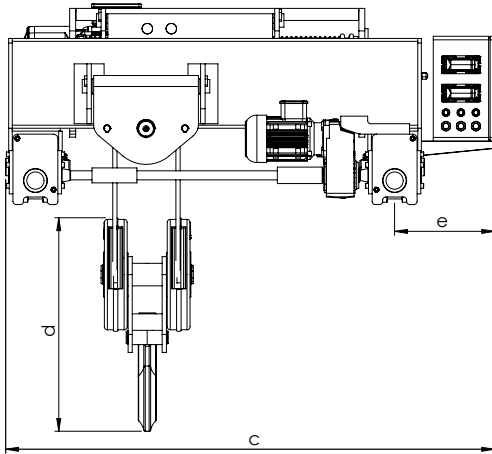
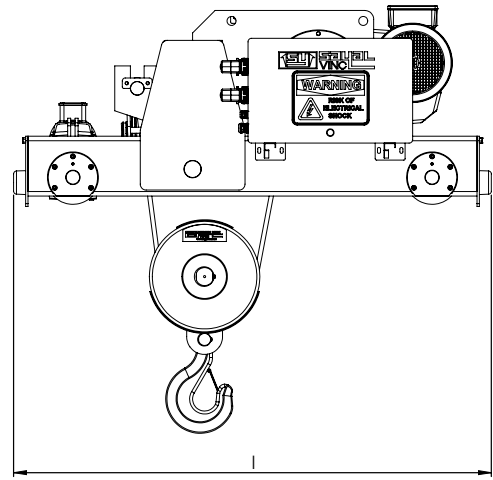
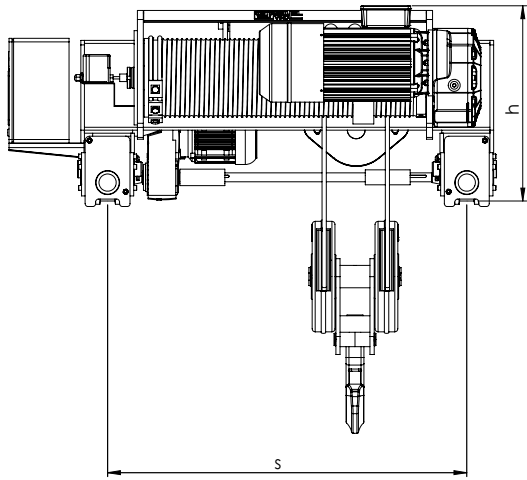

DIMENSIONS
Dimensions

CHASIS Chassis	MODEL Model	h mm	s mm	l mm	c mm	e mm	d mm
SY.12,5 AVB	12500 - 07	490	1400	1600	1850	350	715
	12500 - 10	660	1200	1600	1650	350	715
	12500 - 12	660	1400	1600	1850	350	715



TROLLEY HOISTS

Palan Electrique Avec Chariot

SY.16 AVB

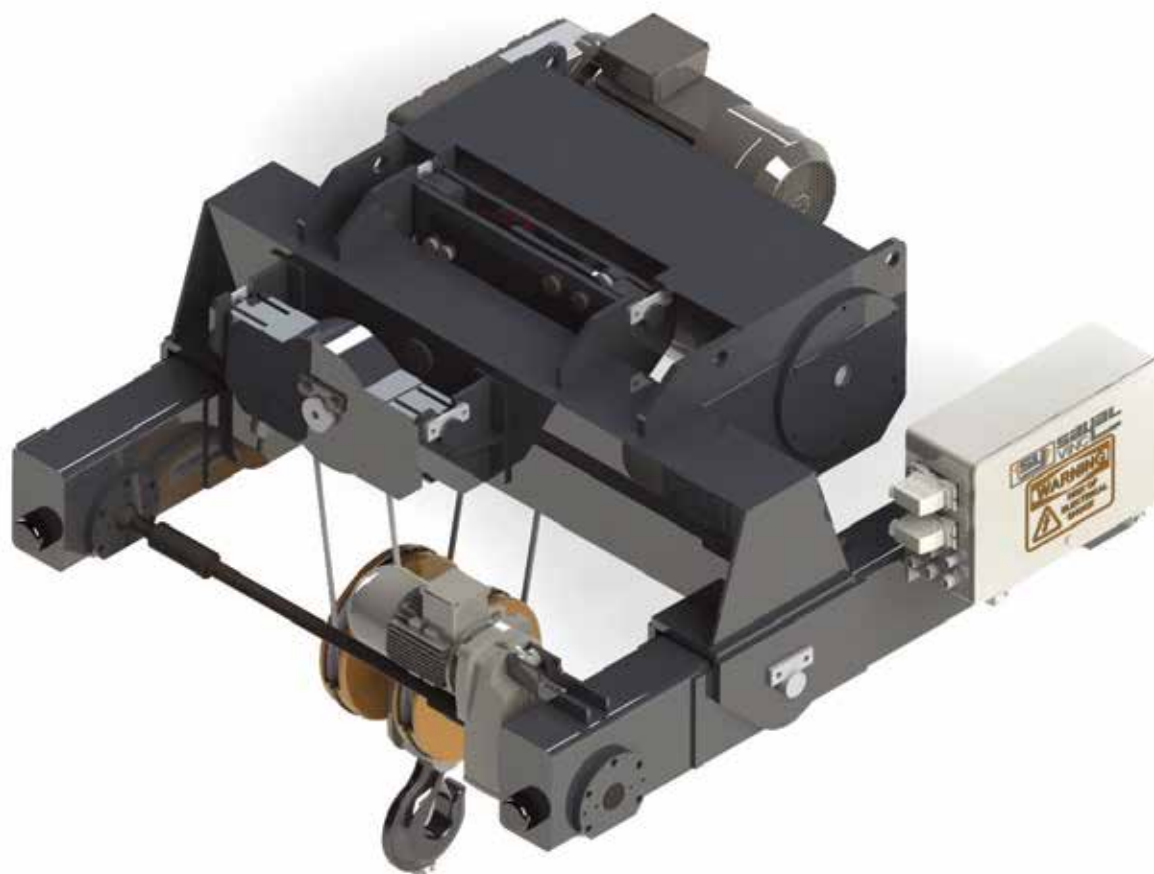

TECHNICAL SPECIFICATIONS Spécifications Techniques

CHASIS Chassis	MODEL Model	TYPE Type	LIFTING CAPACITY (kg) FEM 2M Capacité de levage (kg)	WORKING CLASS	LIFTING HEIGHT (m) Hauteur de levage (m)	LIFTING SPEED TWIN SPEED (m/min.) Vitesse de levage- Vitesse double	TRAVELLING SPEED (m/min.) Vitesse de vehicule (m/min.)	LIFTING MOTOR POWER (kW) Puissance moteur levage (kW)	TRAVELLING MOTOR POWER Puissance moteur vehicule (kW)	ROPE DIAMETER and REEVING Diametre de corde et de équipement
SY.16 AVB	16000 - 07	Double Girder	16000	FEM 2m	7	0,7 / 4	5 / 20	2,6 / 16	1,1	16mm-4/1
	16000 - 10	Double Girder	16000	FEM 2m	10					
	16000 - 12	Double Girder	16000	FEM 2m	12					



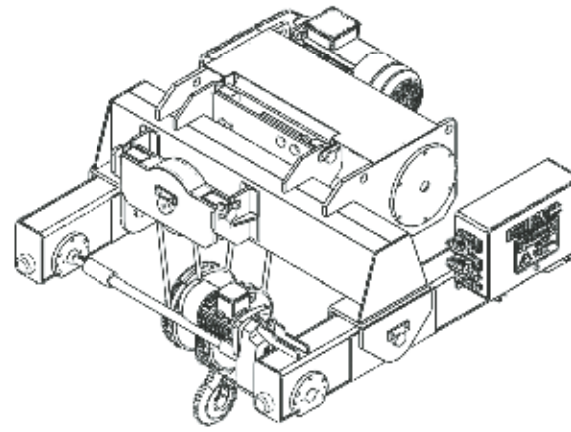
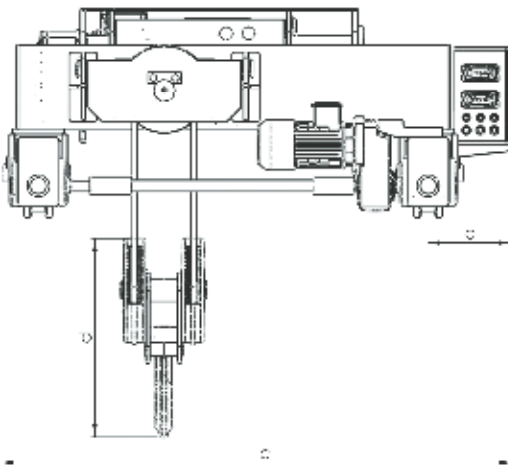
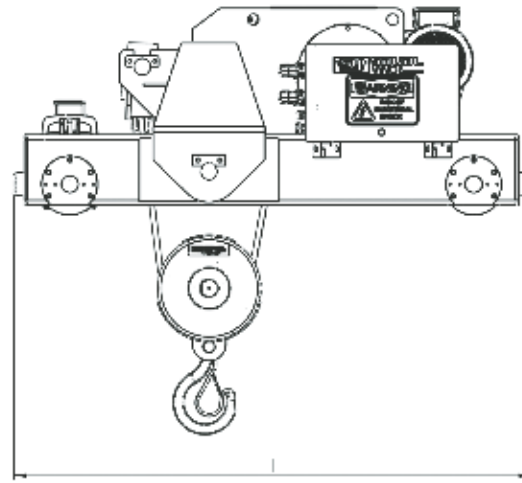
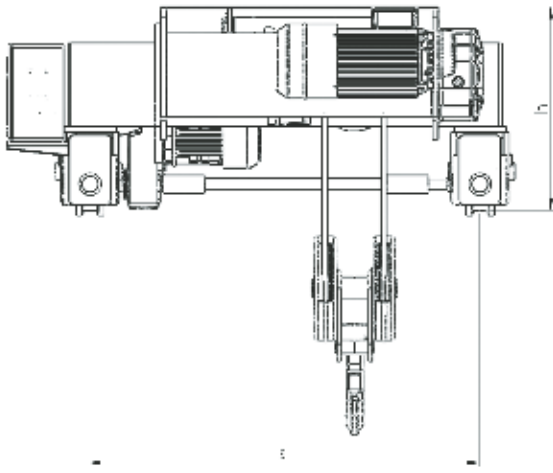

DIMENSIONS
Dimensions

CHASIS Chassis	MODEL Model	h mm	s mm	l mm	c mm	e mm	d mm
SY.16 AVB	16000 - 07	550	1300	1600	1750	350	750
	16000 - 10	550	1500	1600	1950	350	750
	16000 - 12	550	1700	1600	2150	350	750



TROLLEY HOISTS

Palan Electrique Avec Chariot

SY.20 AVB

SY.25 AVB

SY.32 AVB

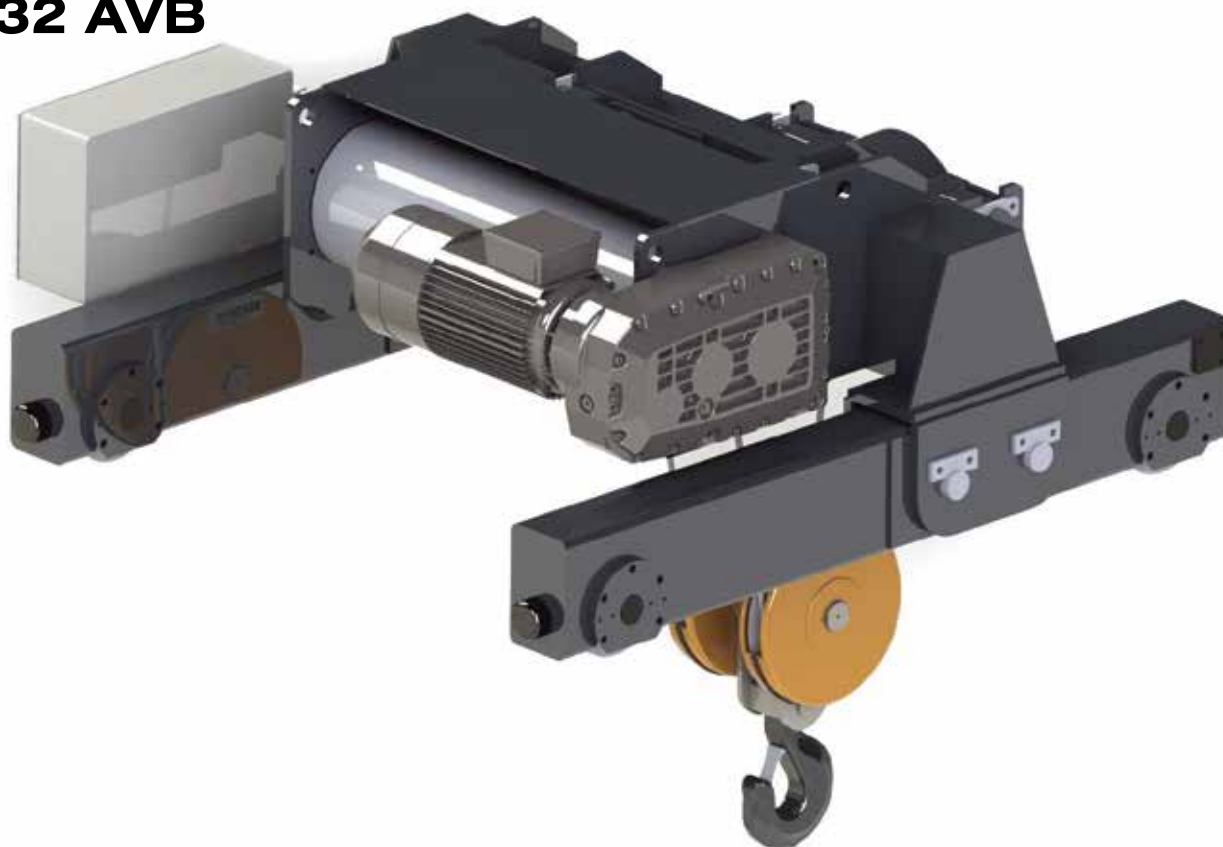

TECHNICAL SPECIFICATIONS Spécifications Techniques

CHASIS Chassis	MODEL Model	TYPE Type	LIFTING CAPACITY (kg) FEM 2M Capacité de levage (kg)	WORKING CLASS	LIFTING HEIGHT (m) Hauteur de levage (m)	LIFTING SPEED TWIN SPEED (m/min.) Vitesse de levage- Vitesse double	TRAVELLING SPEED (m/min.) Vitesse de véhicule (m/min.)	LIFTING MOTOR POWER (kW) Puissance moteur levage (kW)	TRAVELLING MOTOR POWER Puissance moteur véhicule (kW)	ROPE DIAMETER and REEVING Diamètre de corde et de équipement
SY.20 AVB	20000 - 07	Double Girder	20000	FEM 1Am	7	0,7 / 4	5 / 20	2,6 / 16	1,1	18mm-4/1
	20000 - 10	Double Girder	20000	FEM 1Am	10					
	20000 - 12	Double Girder	20000	FEM 1Am	12					
SY.20 AVB	20000 - 07	Double Girder	20000	FEM 2m	7	0,5 / 3, 4	5 / 20	2,6 / 16	1,1	18mm-4/1
	20000 - 10	Double Girder	20000	FEM 2m	10					
	20000 - 12	Double Girder	20000	FEM 2m	12					
SY.25 AVB	25000 - 07	Double Girder	25000	FEM 1Am	7	0,5 / 3, 4	5 / 20	2,6 / 16	2,2	20mm-4/1
	25000 - 10	Double Girder	25000	FEM 1Am	10					
	25000 - 12	Double Girder	25000	FEM 1Am	12					
SY.32 AVB	32000 - 07	Double Girder	32000	FEM 1Am	7	0,3 / 2, 3	5 / 20	2,6 / 16	2,2	18mm-6/1
	32000 - 10	Double Girder	32000	FEM 1Am	10					
	32000 - 12	Double Girder	32000	FEM 1Am	12					

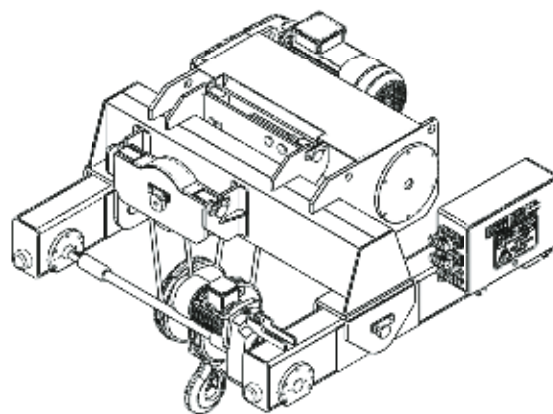
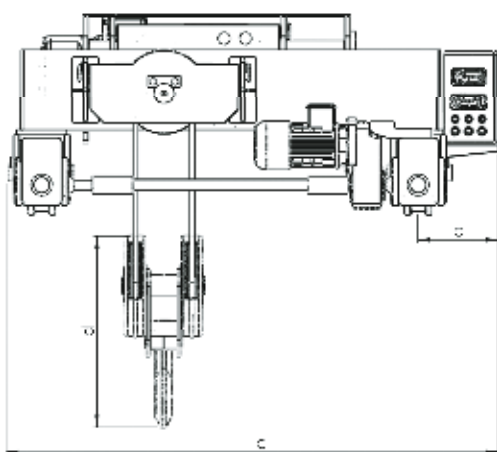
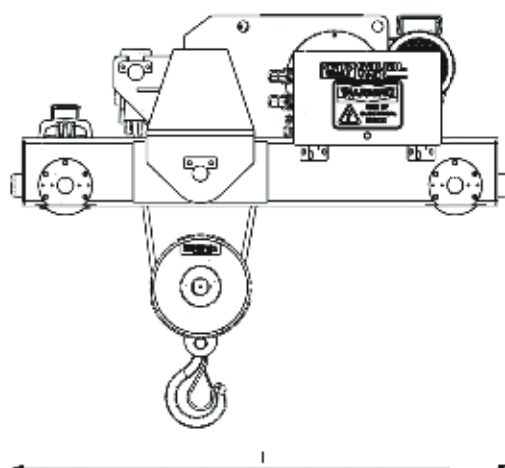
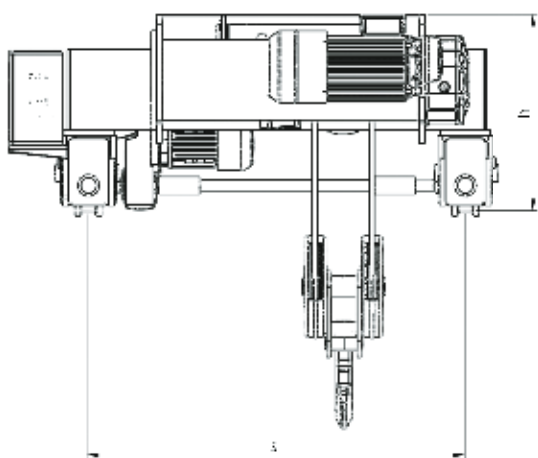

DIMENSIONS
Dimensions

CHASIS Chassis	MODEL Model	h mm	s mm	l mm	c mm	e mm	d mm
SY.20 AVB	20000 - 07	650	1400	1850	1900	400	900
	20000 - 10	650	1600	1850	2100	400	900
	20000 - 12	650	1800	1850	2300	400	900
SY.20 AVB	20000 - 07	775	1200	1850	1700	400	900
	20000 - 10	775	1400	1850	1900	400	900
	20000 - 12	775	1600	1850	2100	400	900
SY.25 AVB	25000 - 07	775	1200	1850	1700	400	950
	25000 - 10	775	1400	1850	1900	400	950
	25000 - 12	775	1600	1850	2100	400	950
SY.32 AVB	32000 - 07	800	1400	1900	1950	425	1150
	32000 - 10	800	1600	1900	2150	425	1150
	32000 - 12	800	1800	1900	2350	425	1150

MONORAIL HOISTS

Grues Monorail

SY.3.2 MV

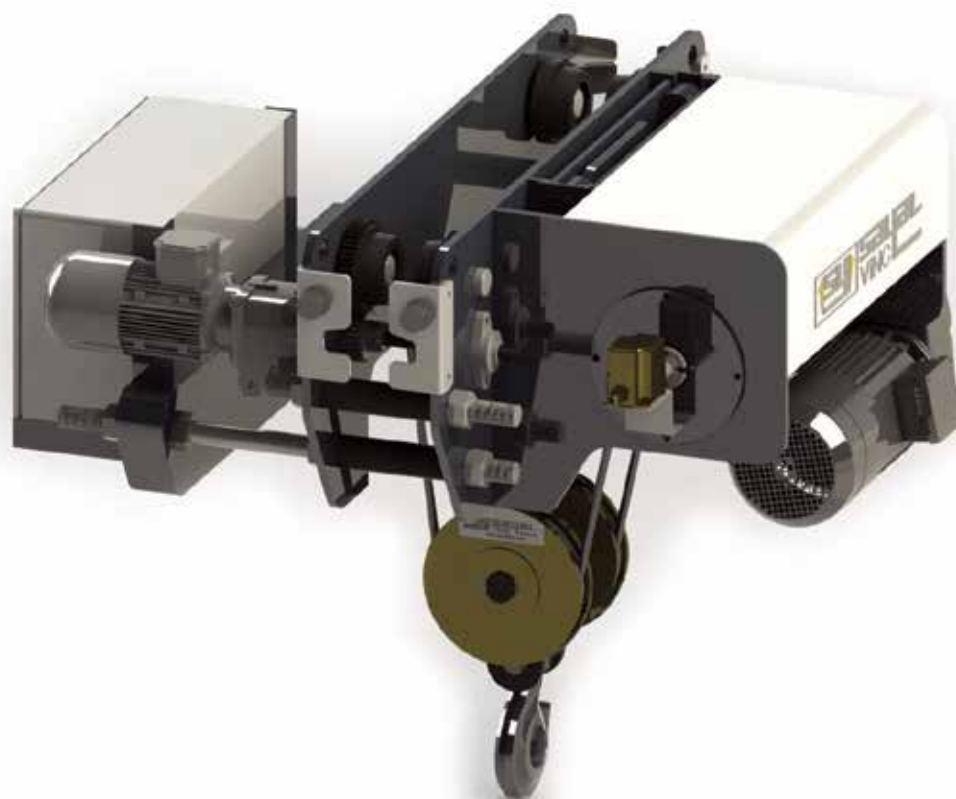

TECHNICAL SPECIFICATIONS Spécifications Techniques

CHASIS Chassis	MODEL Model	TYPE Type	LIFTING CAPACITY (kg) FEM 2M Capacité de levage (kg)	WORKING CLASS	LIFTING HEIGHT (m) Hauteur de levage (m)	LIFTING SPEED TWIN SPEED (m/min.) Vitesse de levage- Vitesse double	TRAVELLING SPEED (m/min.) Vitesse de véhicule (m/min.)	LIFTING MOTOR POWER (kW) Puissance moteur levage (kW)	TRAVELLING MOTOR POWER Puissance moteur véhicule (kW)	ROPE DIAMETER and REEVING Diamètre de corde et de équipement
SY.3,2 MV	3200-07 3200-10	Single Girder Single Girder	3200 3200	FEM 2m FEM 2m	7 10	0,6 / 3,9	5 / 20	0,37 / 2,5	0,55	8mm-4/1



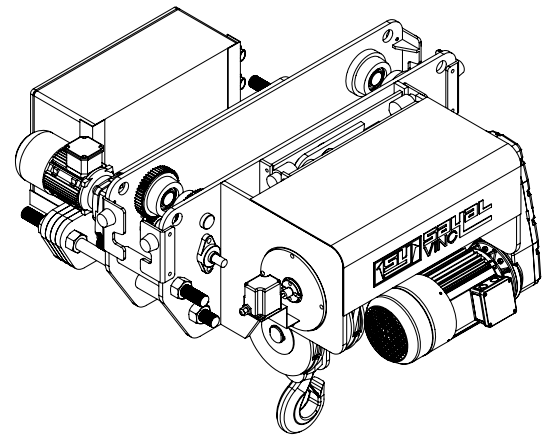
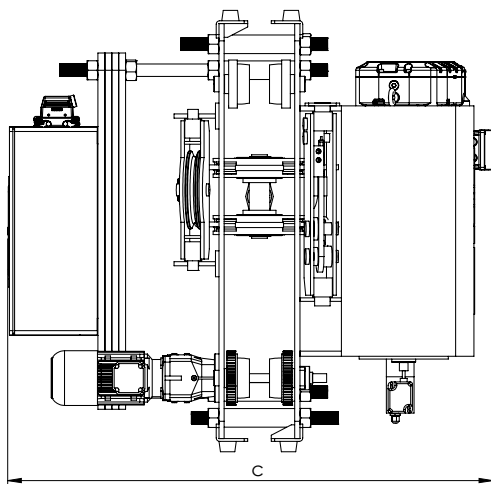
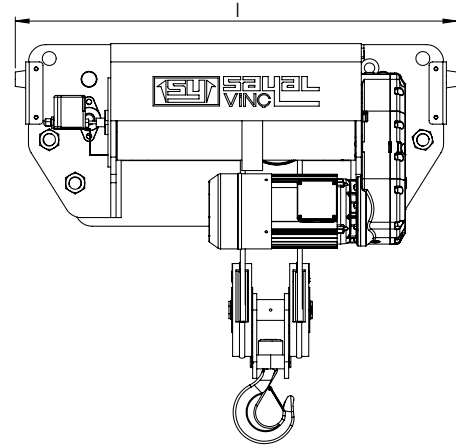
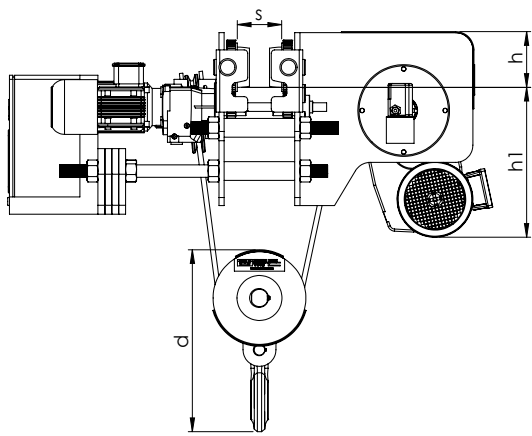

DIMENSIONS
Dimensions

CHASIS Chassis	MODEL Model	h mm	s mm	l mm	c mm	e mm	d mm
SY.3.2 MV	3200 - 07	200 - 350	175	400	1355	530	1150
	3200 - 10	200 - 350	175	400	1355	530	1400



MONORAIL HOISTS

Grues Monorail

SY.5 MV SY.6.3 MV



TECHNICAL SPECIFICATIONS Spécifications Techniques

CHASIS Chassis	MODEL Model	TYPE Type	LIFTING CAPACITY (kg) FEM 2M Capacité de levage (kg)	WORKING CLASS	LIFTING HEIGHT (m) Hauteur de levage (m)	LIFTING SPEED TWIN SPEED (m/min.) Vitesse de levage- Vitesse double	TRAVELLING SPEED (m/min.) Vitesse de véhicule (m/min.)	LIFTING MOTOR POWER (kW) Puissance moteur levage (kW)	TRAVELLING MOTOR POWER Puissance moteur véhicule (kW)	ROPE DIAMETER and REEVING Diamètre de corde et de équipement
SY.5 MV	5000 - 07	Single Girder	5000	FEM 2m	7	0,8 / 5,2	5 / 20	0,8 / 4,9	0,75	10mm-4/1
	5000 - 10	Single Girder	5000	FEM 2m	10					
	5000 - 12	Single Girder	5000	FEM 2m	12					
SY.6.3 MV	6300 - 07	Single Girder	6300	FEM 2m	7	0,7 / 4,2	5 / 20	0,8 / 4,9	0,75	10mm-4/1
	6300 - 10	Single Girder	6300	FEM 2m	10					
	6300 - 12	Single Girder	6300	FEM 2m	12					



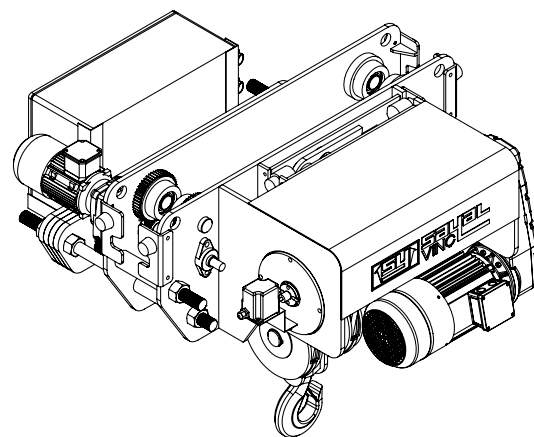
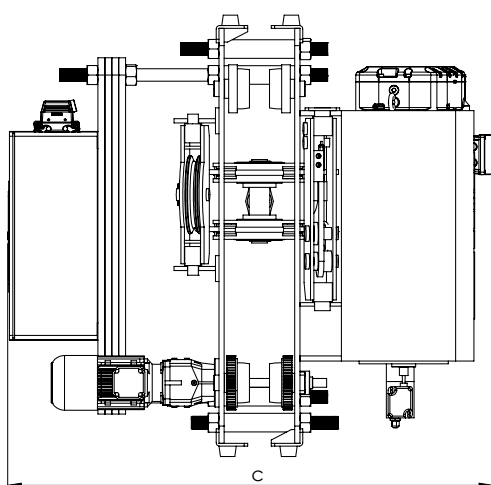
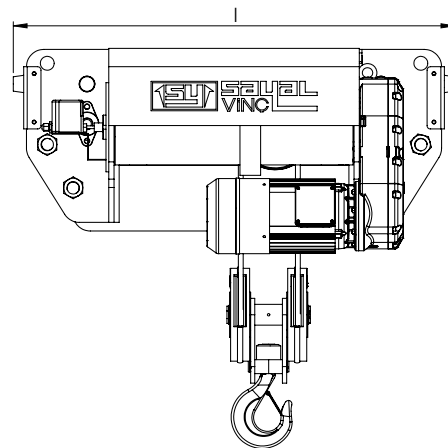
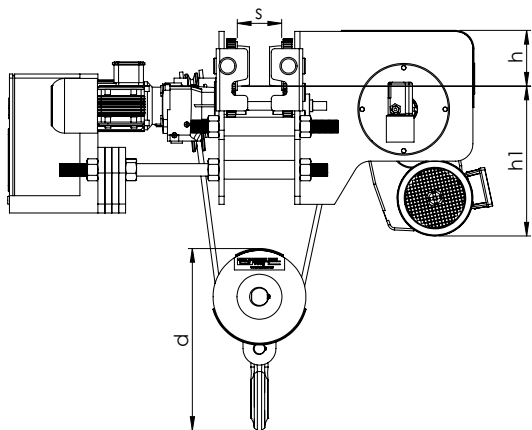

DIMENSIONS
Dimensions

CHASIS Chassis	MODEL Model	h mm	s mm	l mm	c mm	e mm	d mm
SY. 5 MV	5000 - 07	200 - 350	200	450	1500	530	1200
	5000 - 10	200 - 350	200	450	1500	530	1400
	5000 - 12	200 - 350	200	450	1500	530	1500
SY. 6,3 MV	6300 - 07	200 - 350	200	450	1500	530	1200
	6300 - 10	200 - 350	200	450	1500	530	1400
	6300 - 12	200 - 350	200	450	1500	530	1500



MONORAIL HOISTS

Grues Monorail

SY.10 MV



TECHNICAL SPECIFICATIONS Spécifications Techniques

CHASIS Chassis	MODEL Model	TYPE Type	LIFTING CAPACITY (kg) FEM 2M Capacité de levage (kg)	WORKING CLASS	LIFTING HEIGHT (m) Hauteur de levage (m)	LIFTING SPEED TWIN SPEED (m/min.) Vitesse de levage- Vitesse double	TRAVELLING SPEED (m/min.) Vitesse de véhicule (m/min.)	LIFTING MOTOR POWER (kW) Puissance moteur levage (kW)	TRAVELLING MOTOR POWER Puissance moteur véhicule (kW)	ROPE DIAMETER and REEVING Diamètre de corde et de équipement
SY.10 MV	10000 - 07	Single Girder	10000	FEM 2m	7	0,7 / 4	5 / 20	1,5 / 9,5	1,1	14mm-4/1
	10000 - 10	Single Girder	10000	FEM 2m	10					
	10000 - 12	Single Girder	10000	FEM 2m	12					



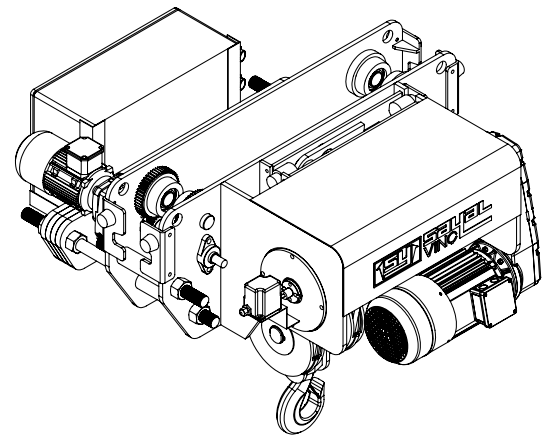
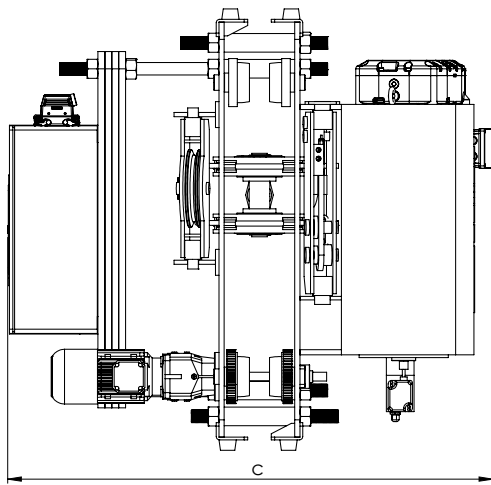
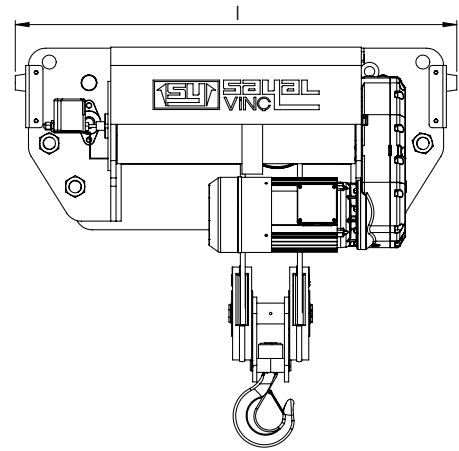
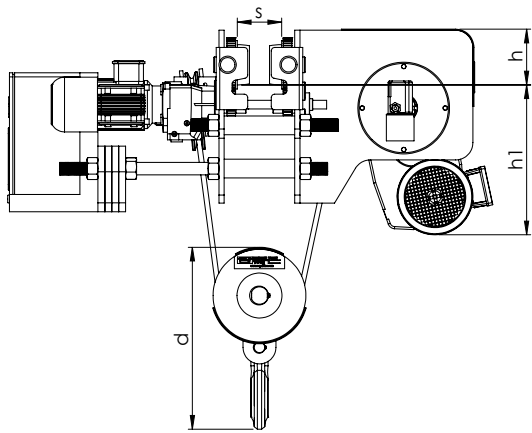

DIMENSIONS
Dimensions

CHASIS Chassis	MODEL Model	h mm	s mm	l mm	c mm	e mm	d mm
SY. 10 MV	10000 - 07	300 - 450	275	850	1700	715	1400
	10000 - 10	300 - 450	275	850	1700	715	1600
	10000 - 12	300 - 450	275	850	1700	715	1750



ENDCARRIAGES SELECTION TABLE

Tableau de Sélection des Sommiers

For Double Girder Overhead Travelling Crane

Pour Pont Roulant Bipoutre

 kg	50000	4020.GT.B.U.6				4020.GT.B.U.8		5025.GT.B.U.8		
	40000	4020.GT.U.5				4020.GT.B.U.6				
	32000	3020.GT.U.5		4020.GT.U.5		4020.GT.B.U.6				
	25000	3020.GT.4		3020.GT.5	3020.GT.U.5		4020.GT.U.5			
	20000	2515.GT.4		3020.GT.4		3020.GT.5	3020.GT.U.5	4020.GT.U.5		
	16000	2515.GT.4		3020.GT.4		3020.GT.5	3020.GT.U.5			
	12500	2515.GT.4		3020.GT.4		3020.GT.5	3020.GT.U.5			
	10000	2015.GT.4		2515.GT.4	3020.GT.4		3020.GT.5	3020.GT.U.5		
	6300	2015.GT.4		2515.GT.4		3020.GT.4				
	5000	2015.GT.4		2515.GT.4		3020.GT.4				
	3200	2015.GT.3		2015.GT.4		2515.GT.4	3020.GT.4			
	2000	2015.GT.3		2015.GT.4		2515.GT.4	3020.GT.4			
	<p style="text-align: center;">Span L (m) Entraxe L (m)</p>									

For Single Girder Overhead Travelling Crane

Pour Pont Roulant Monopoutre

 kg	16000	2515.GT.4		3020.GT.4		3020.GT.5	3020.GT.U.5		
	12500	2515.GT.4		3020.GT.4		3020.GT.5	3020.GT.U.5		
	10000	2015.GT.4		2515.GT.4	3020.GT.4		3020.GT.5		
	6300	2015.GT.4		2515.GT.4		3020.GT.4			
	5000	2015.GT.4		2515.GT.4		3020.GT.4			
	3200	2015.GT.3		2015.GT.4		2515.GT.4			
	2000	2015.GT.3		2015.GT.4		2515.GT.4			
<p style="text-align: center;">Span L (m) Entraxe L (m)</p>									



ENDCARRIAGES FOR DOUBLE GIRDER O.H.T. CRANES

SOMMIERS POUR PONTS ROULANTS BIPOUTRE

2015.GT.X

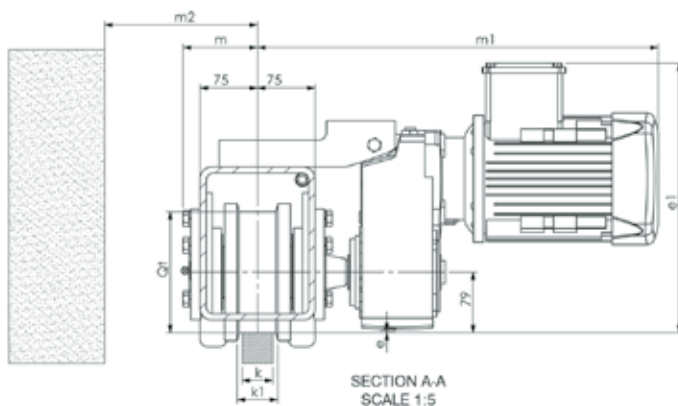
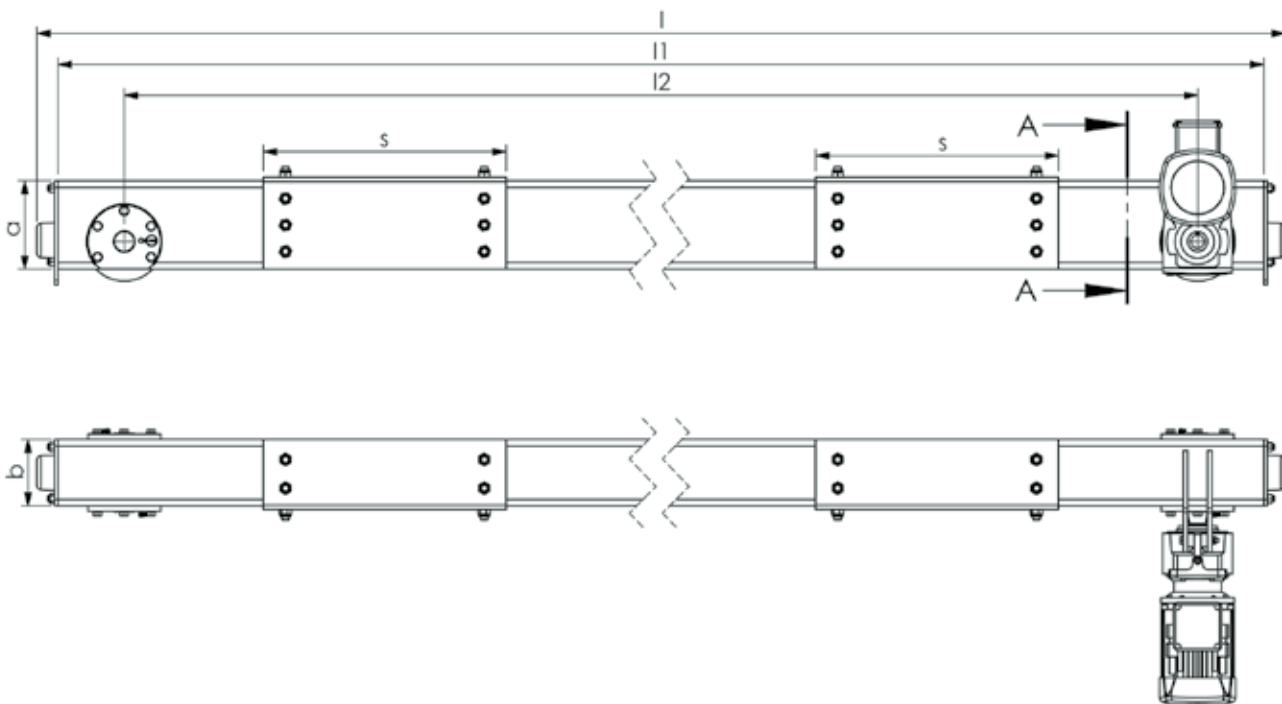

TYPE	k	k1
2015.GT.4	40	48
2015.GT.3	30	38

TYPE	Qt	a	b	l	l1	l2	s	m	m2	Pm,kW	e	m1	e1
2015.GT.X	Ø158	200	150	2596-3096	2500-3000	2200-2700	400-550	100	150	0,55	8	480	310
										0,75	2,5	500	330
										1.1	2,5	530	355



ENDCARRIAGES FOR DOUBLE GIRDER O.H.T. CRANES SOMMIERS POUR PONTS ROULANTS BIPOUTRE

2515.GT.X

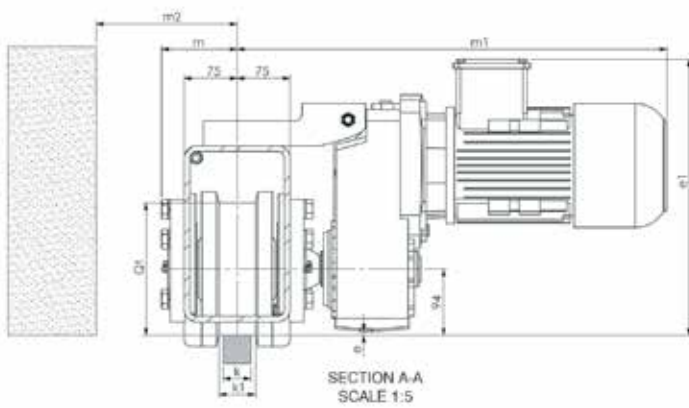
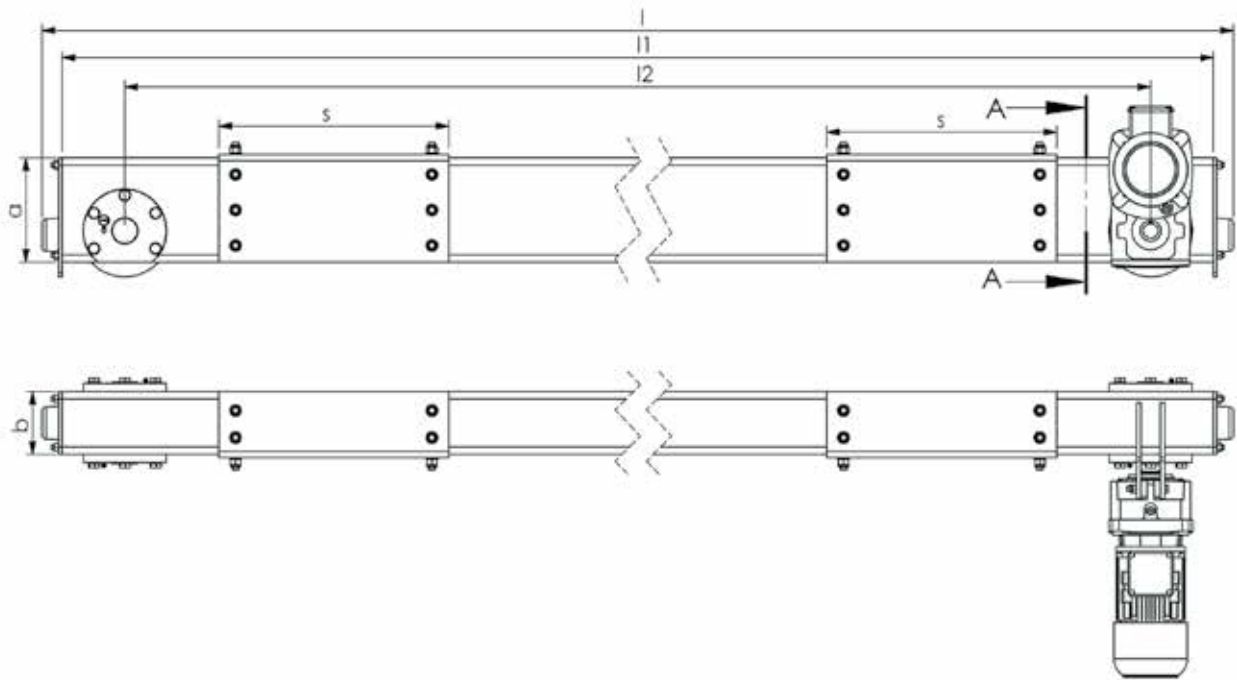

TYPE	k	k1
2515.GT.4	40	48

TYPE	Qt	a	b	l	l1	l2	s	m	m2	Pm,kW	e	m1	e1
2515.GT.X	Ø188	250	150	2596-3096	2500-3000	2200-2700	400-550	110	150	1,1	5,5	610	395



ENDCARRIAGES FOR DOUBLE GIRDER O.H.T. CRANES SOMMIERS POUR PONTS ROULANTS BIPOUTRE

3020.GT.X

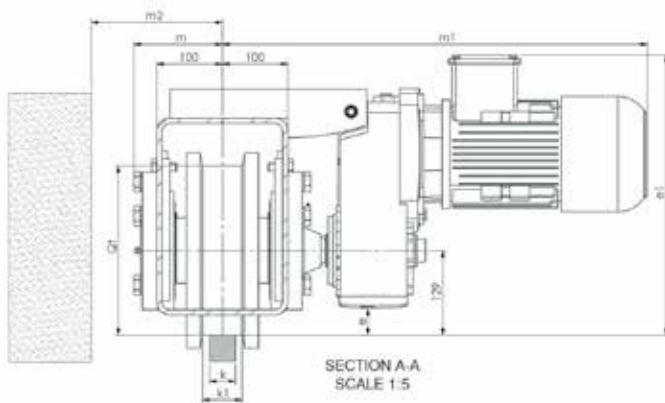
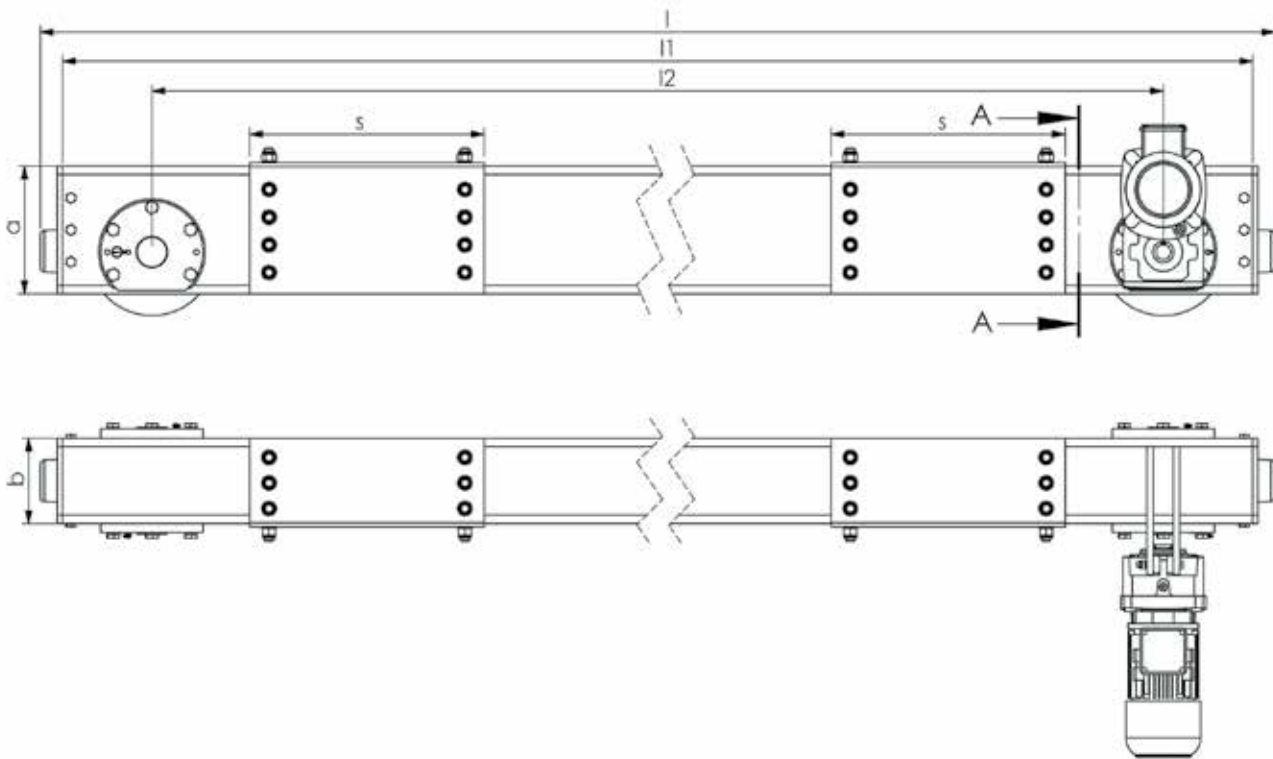

TYPE	k	k1
3020.GT.4	40	60
3020.GT.5	50	65

TYPE	Qt	a	b	l	l1	l2	s	m	m2	Pm,kW	e	m1	e1
3020.GT.X	Ø258	300	200	2596-3596	2500-3500	2080-3080	500-650	135	180	1,1	40,5	650	430
										1,5	24	690	460
										2,2	24,5	640	467



ENDCARRIAGES FOR DOUBLE GIRDER O.H.T. CRANES SOMMIERS POUR PONTS ROULANTS BIPOUTRE

3020.GT.U.X

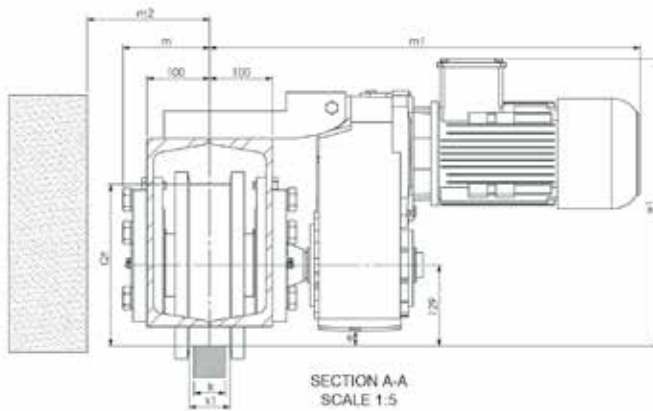
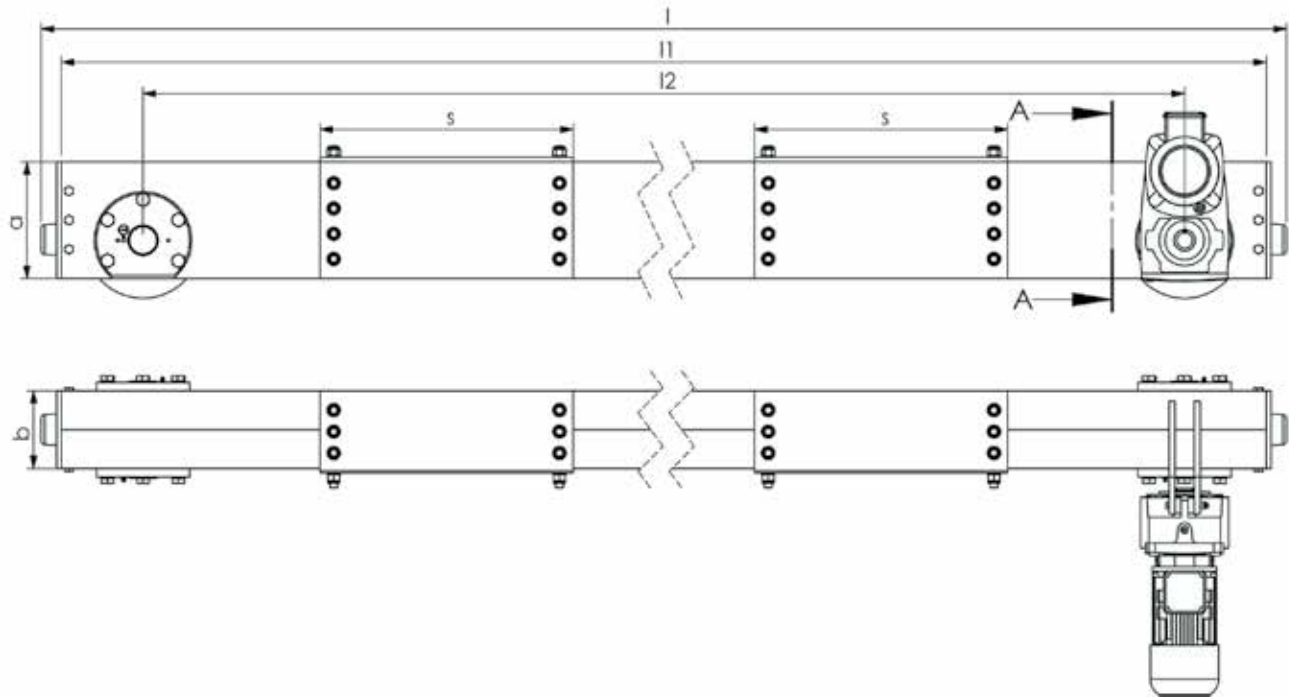

TYPE	k	k1
3020.GT.U.5	50	65

TYPE	Qt	a	b	l	l1	l2	s	m	m2	Pm,kW	e	m1	e1
3020.GT.U.X	Ø258	300	200	3104-4104	3000-4000	2580-3580	550-650	140	185	1,5	24	690	460
										2,2	24,5	640	467
										3	9,5	741	495
										4	8	785	503

ENDCARRIAGES FOR DOUBLE GIRDER O.H.T. CRANES

SOMMIERS POUR PONTS ROULANTS BIPOUTRE

4020.GT.U.X

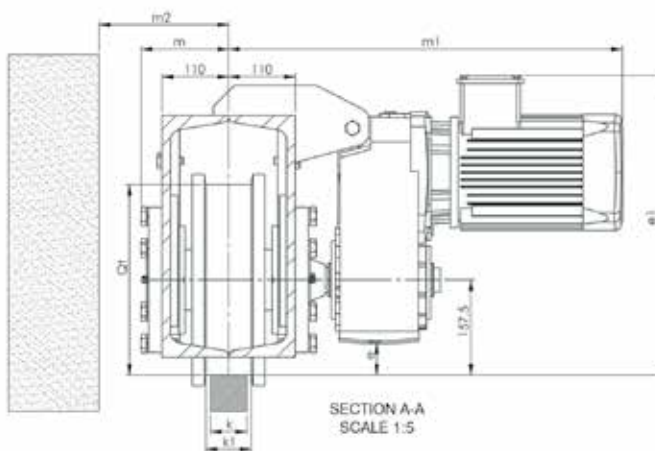
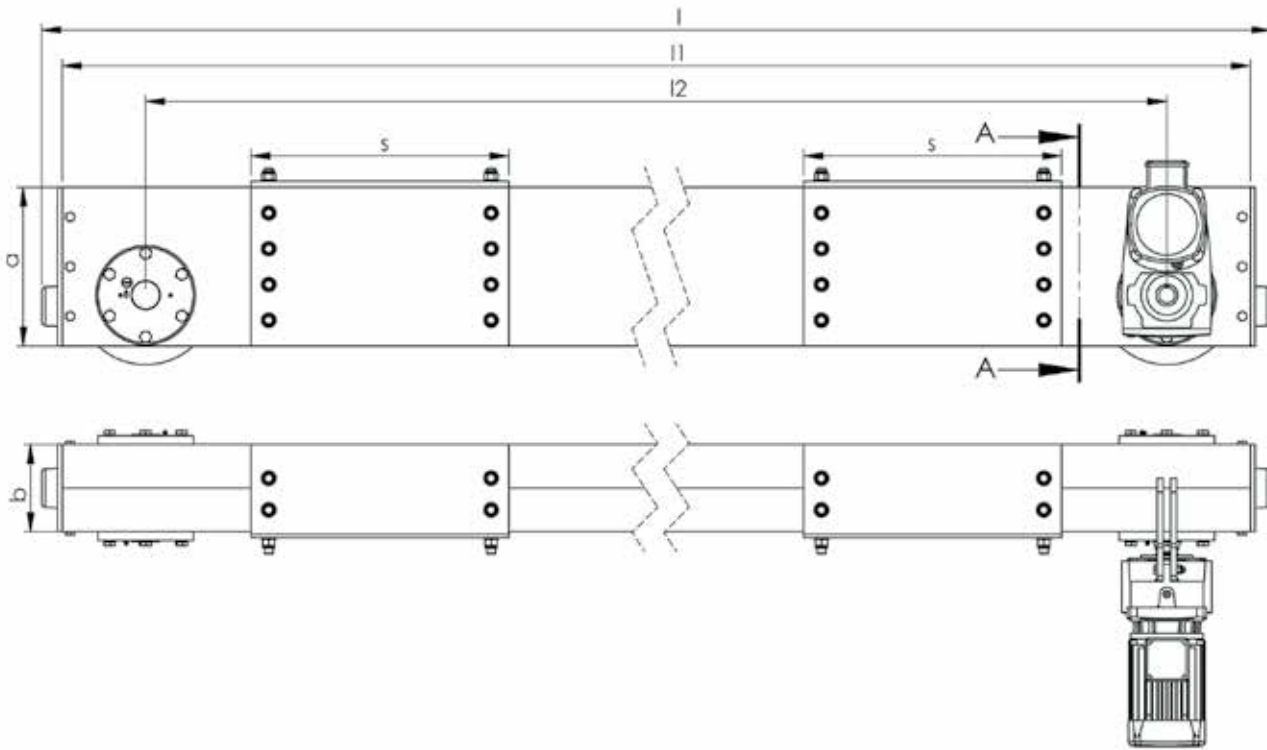

TYPE	k	k1
4020.GT.U.5	50	65

TYPE	Qt	a	b	l	l1	l2	s	m	m2	Pm,kW	e	m1	e1
4020.GT.U.X	Ø315	400	220	3604-4604	3500-4500	3080-4080	550-750	145	210	2,2	53	651	495
										3	36,5	751	523,5
										4	35	795	531,5
										5	13,5	844	590,5

ENDCARRIAGES FOR DOUBLE GIRDER O.H.T. CRANES SOMMIERS POUR PONTS ROULANTS BIPOUTRE

4020.GT.B.U.X

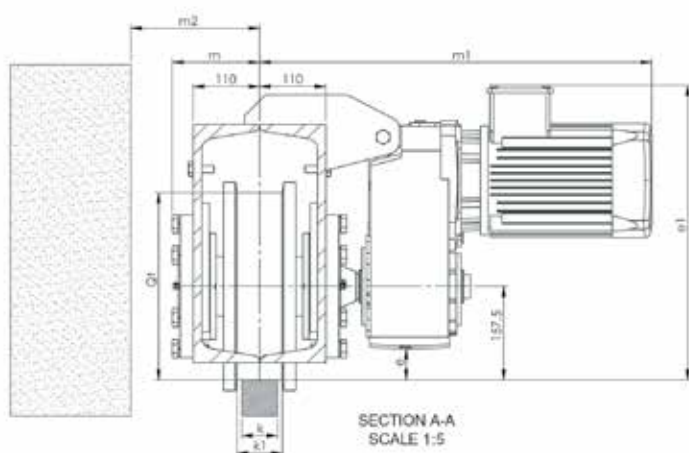
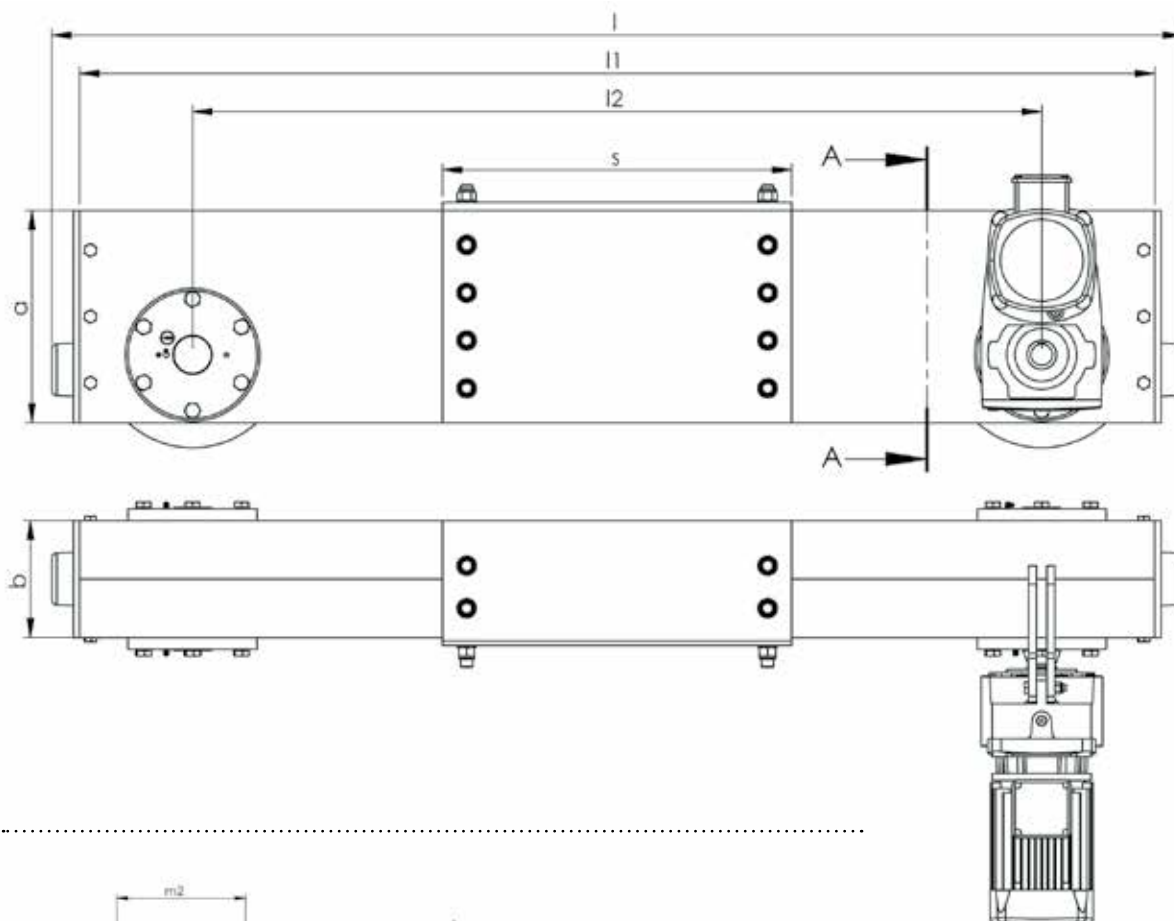

TYPE	k	k1
4020.GT.U.6	60	75
4020.GT.U.8	80	95

TYPE	Qt	a	b	l	l1	l2	s	m	m2	Pm,kW	e	m1	e1
4020.GT.U.X	Ø315	400	220	2104-3104	2000-3000	1580-2580	550-750	145	230	2,2	53	651	495
										3	36,5	751	523,5
										4	35	795	531,5
										5	13,5	844	590,5

ENDCARRIAGES FOR DOUBLE GIRDER O.H.T. CRANES SOMMIERS POUR PONTS ROULANTS BIPOUTRE

5025.GT.B.U.X

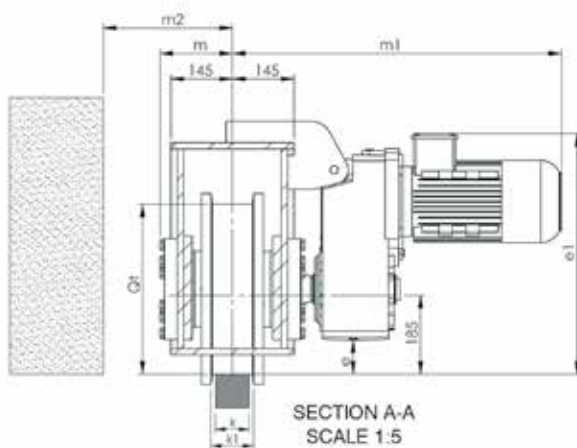
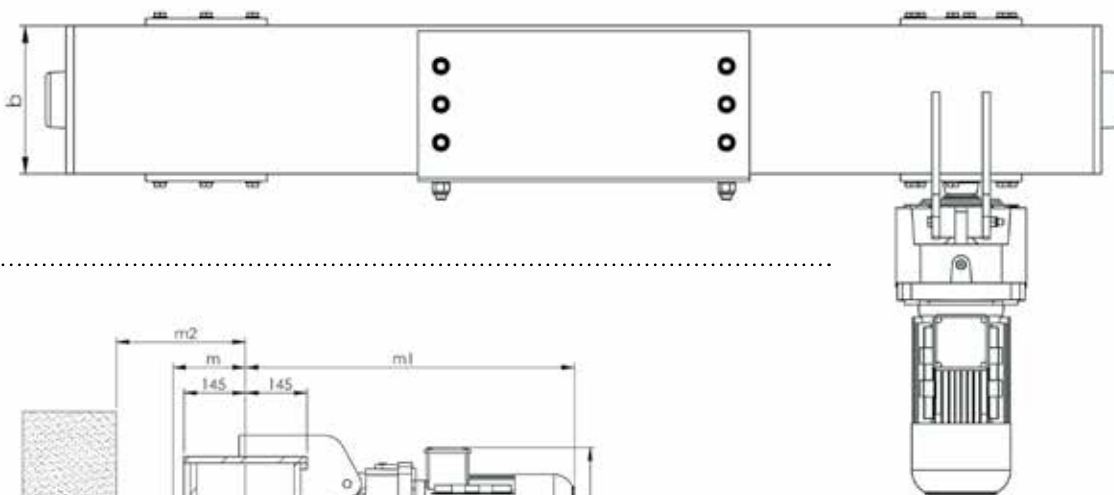
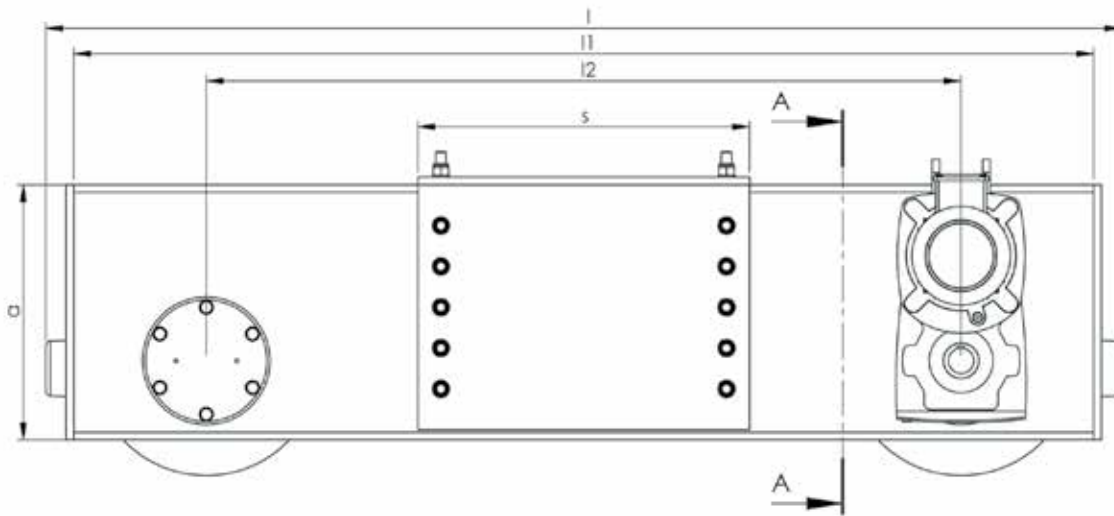

TYPE	k	k1
5025.GT.B.U.8	80	95

TYPE	Qt	a	b	l	l1	l2	s	m	m2	Pm,kW	e	m1	e1
5025.GT.B.U.X	Ø400	500	290	2110-2610	2000-2500	1480-1980	550-800	175	230	2,2	95,5	675,5	538
										3	79	775,5	566
										4	79	819,5	574
										5	56,5	868,5	632,9

ENDCARRIAGES FOR SINGLE GIRDER O.H.T. CRANES SOMMIERS POUR PONTS ROULANTS MONOPOUTRE

2015.GT.X

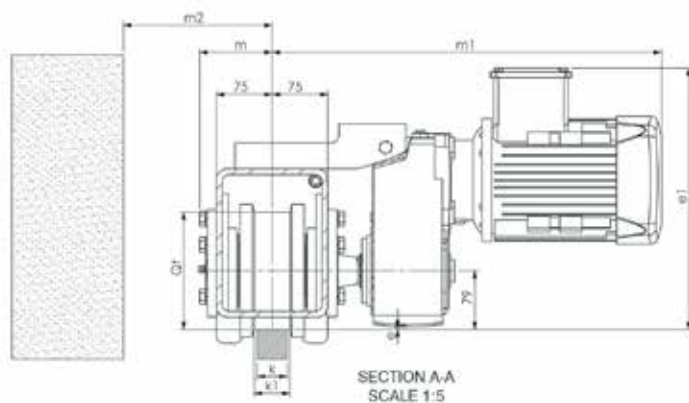
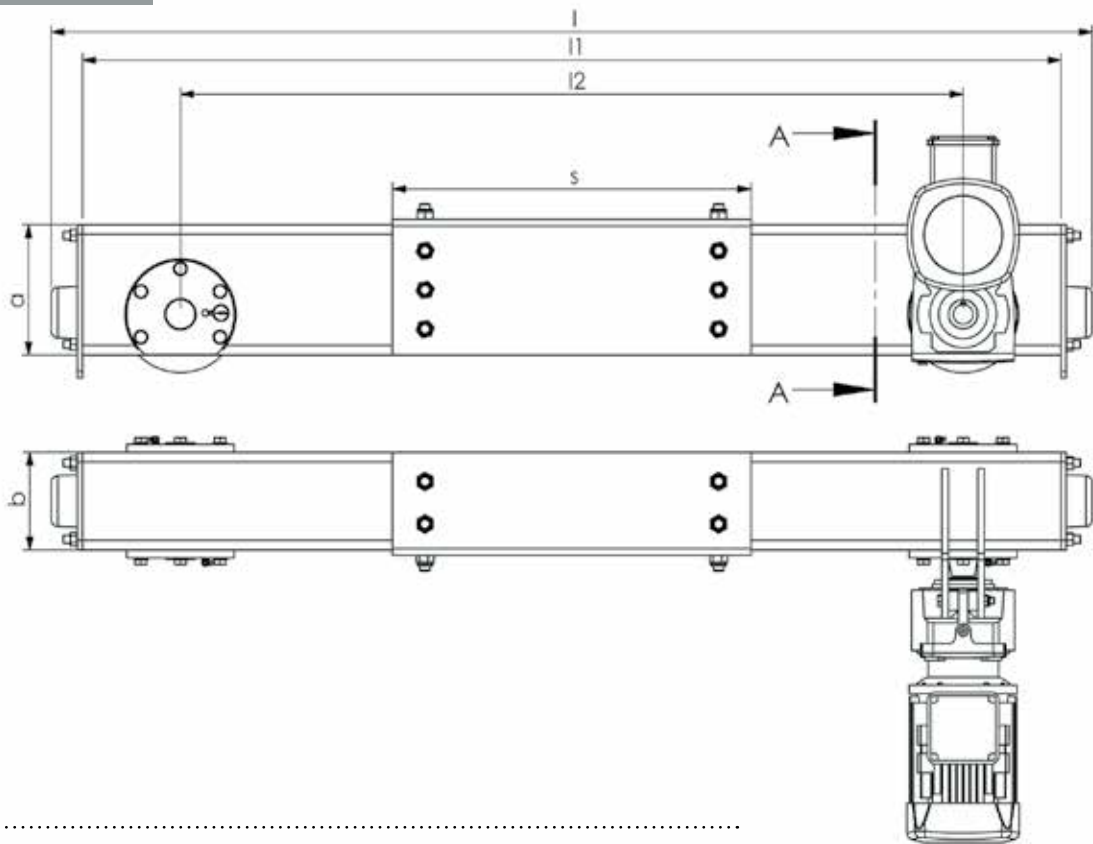

TYPE	k	k1
2015.GT.4	40	48
2015.GT.3	30	38

TYPE	Qt	a	b	l	l1	l2	s	m	m2	Pm,kW	e	m1	e1
2015.GT.X	Ø158	200	150	1096-1596	1000-1500	700-1200	300-450	100	150	0,55	8	480	310
										0,75	2,5	500	330
										1.1	2,5	530	355

ENDCARRIAGES FOR SINGLE GIRDER O.H.T. CRANES SOMMIERS POUR PONTS ROULANTS MONOPOUTRE

2515.GT.X

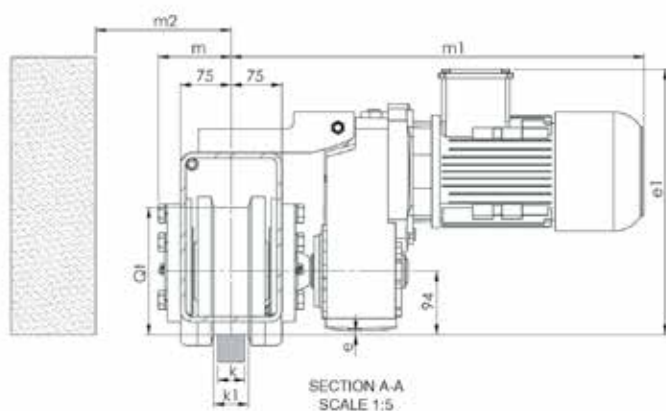
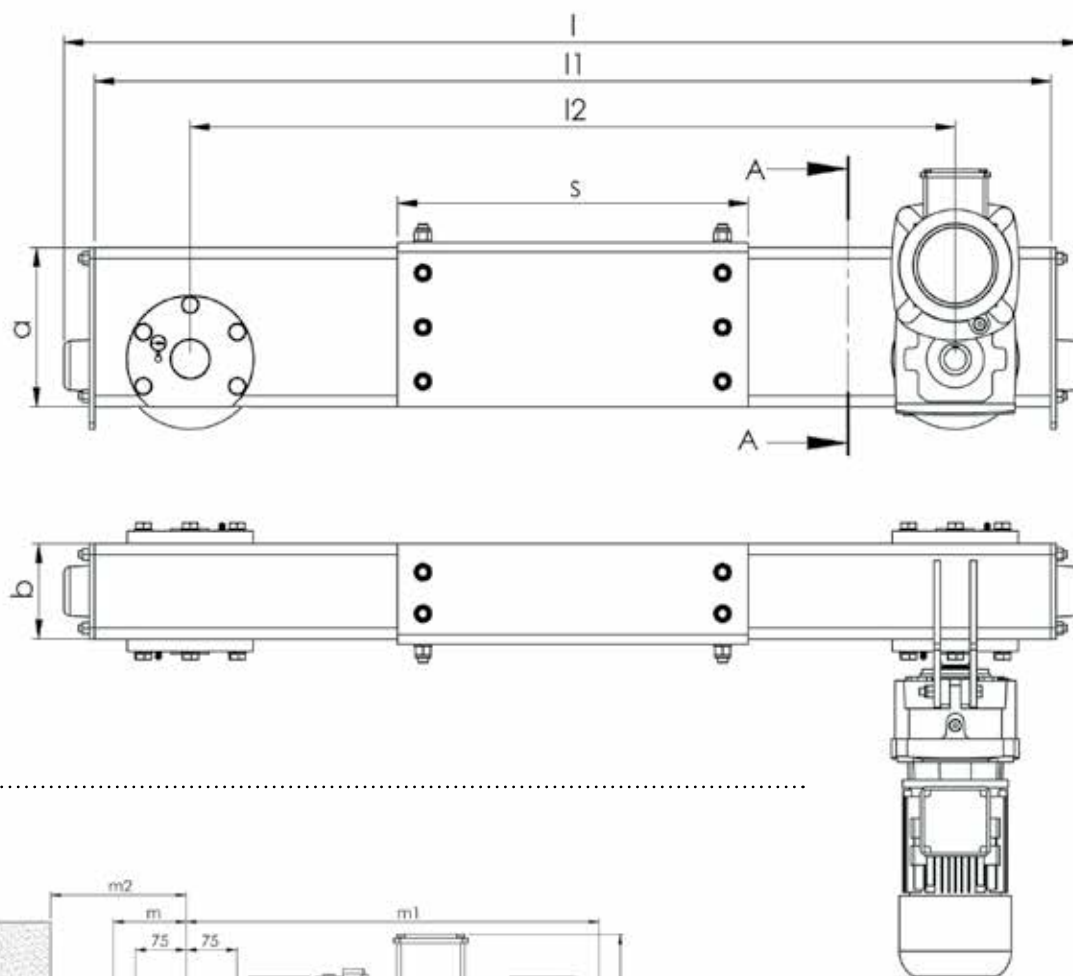

TYPE	k	k1
2515.GT.4	40	52

TYPE	Qt	a	b	l	l1	l2	s	m	m2	Pm,kW	e	m1	e1
2515.GT.X	Ø188	250	150	1596-2096	1500-2000	1200-2700	300-550	110	150	1,1	5,5	610	395



ENDCARRIAGES FOR SINGLE GIRDER O.H.T. CRANES SOMMIERS POUR PONTS ROULANTS MONOPOUTRE

3020.GT.X

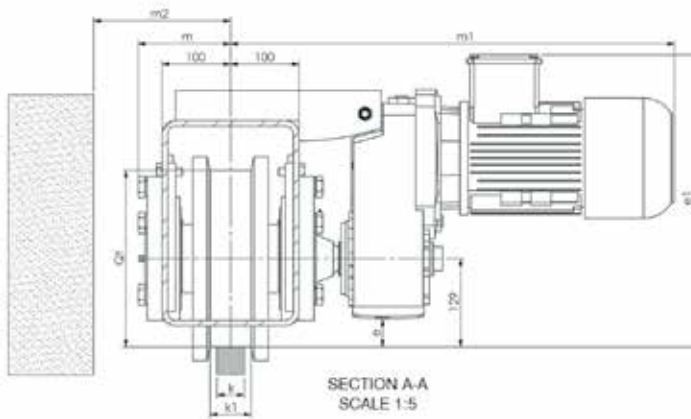
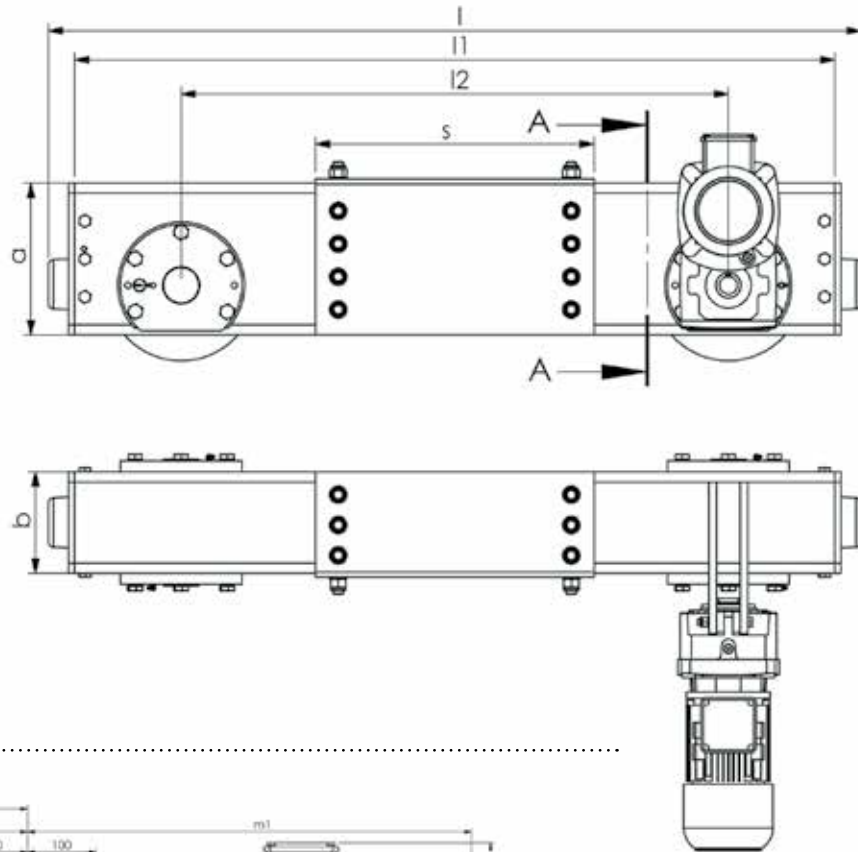

TYPE	k	k1
3020.GT.4	40	60
3020.GT.5	50	65

TYPE	Qt	a	b	l	l1	l2	s	m	m2	Pm,kW	e	m1	e1
3020.GT.X	Ø258	300	200	1604-2104	1500-2000	1080-1580	400-650	135	180	1,1	40,5	650	430
										1,5	24	690	460
										2,2	24,5	640	467

ENDCARRIAGES FOR SINGLE GIRDER O.H.T. CRANES SOMMIERS POUR PONTS ROULANTS MONOPOUTRE

3020.GT.U.X

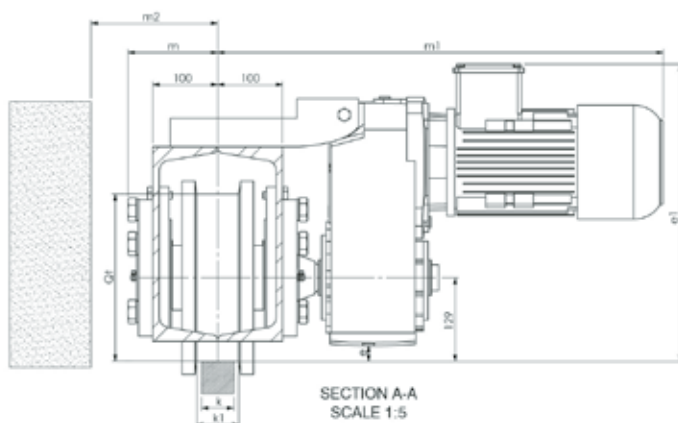
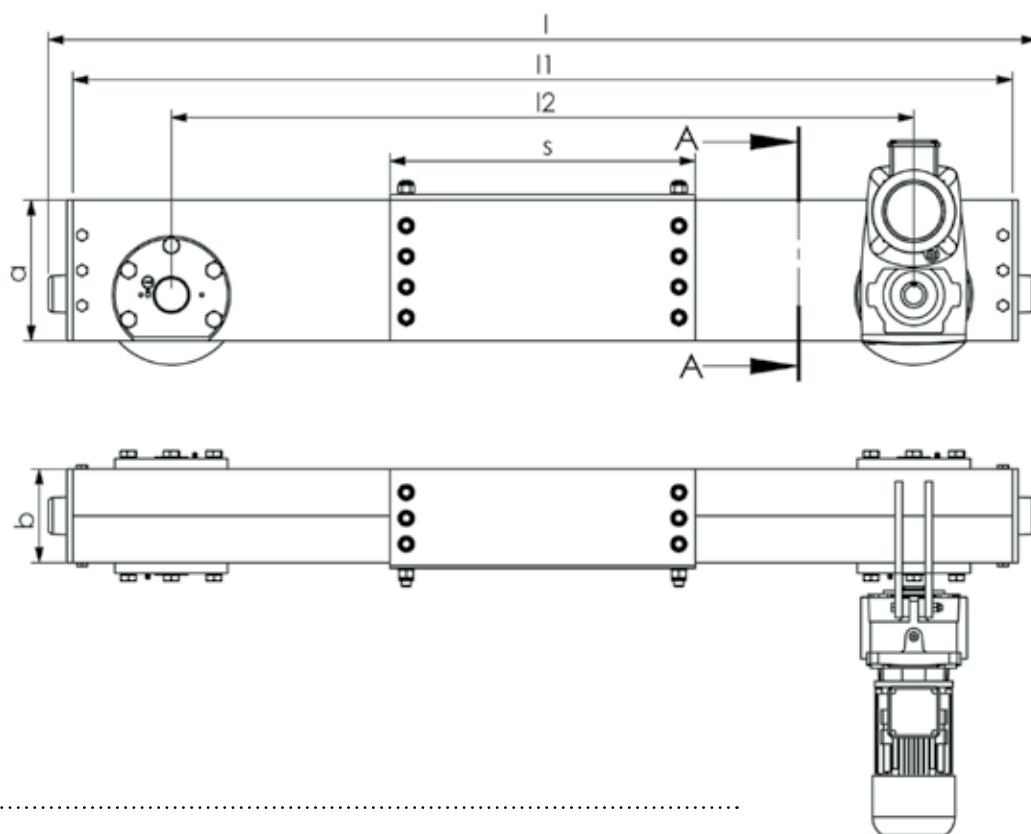

TYPE	k	k1
3020.GT.U.5	50	65

TYPE	Qt	a	b	l	l1	l2	s	m	m2	Pm,kW	e	m1	e1
3020.GT.U.X	Ø258	300	200	1604-2104	1500-2000	1080-1580	550-650	140	185	1,5	24	690	460
										2,2	24,5	640	467
										3	9,5	741	495
										4	8	785	503



SPARE PARTS
PIÈCE DÉTACHÉE



BUSBAR SYSTEM & COLLECTOR
SYSTÈME DE BARRES & COLLECTOR



CABLE REEL
CABLE REEL



HOOK BLOCK
CROCHET BLOC



JOYSTICK CONTROLS
COMMANDES
PAR MANIPULATEUR



REMOTE CONTROL
TÉLÉCOMMANDE



FESTOON LINE
FESTOON LINE











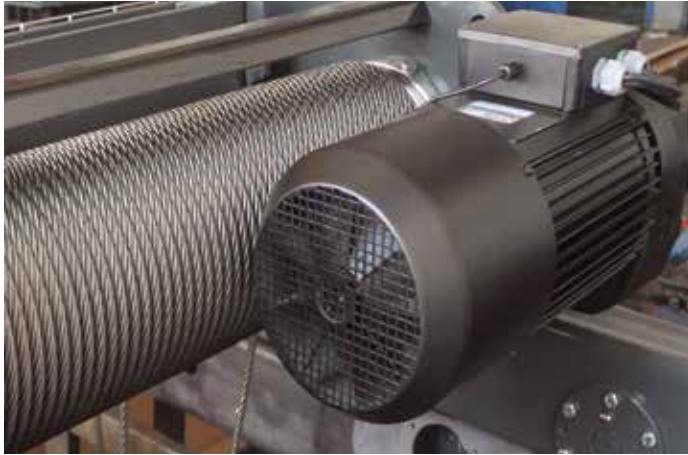



SAYAL VİNÇ MAKİNA San. Tic. Ltd. Şti.

CORPORATE HEADQUARTERS & FACTORY

ASO 1. Organize Sanayi Bölgesi
Ahi Evran Mah. Oğuz Cad. No:41
Sincan / Ankara / Türkiye

Phone : +90(312) 385 67 59

Fax : +90(312) 354 58 69

e-mail : info@sayalvinc.com

www.sayalvinc.com • www.sayalcrane.com

